



Neo-cool Circulator

Model

CF300/701/1100

Instruction Manual

- Fourth Edition -

- Thank you for purchasing "Neo-cool Circulator, CF Series" of Yamato Scientific Co., Ltd.
- To use this unit properly, read this "Instruction Manual" thoroughly before using this unit.
Keep this instruction manual around this unit for referring at anytime.



WARNING!:

Carefully read and thoroughly understand the important warning items described in this manual before using this unit.

Yamato Scientific Co. LTD.,

This paper has been printed on recycled paper.

Contents

◆ Cautions in Using with Safety	1
• Explanation.....	1
• Table of Illustrated Symbols	2
• Fundamental Matters of “WARNING!” and “CAUTION!”	3
• Fundamental Matters of “WARNING!” and “CAUTION!”	4
◆ Before Using this unit	5
• Requirements for Installation.....	5
◆ Description and Function of Each Part	8
• Main Unit and Control panel.....	8
◆ Installation Method	9
◆ Operation Method	11
• Procedure of Operation	11
◆ Handling Precautions	12
◆ Maintenance Method	13
• Daily Inspection and Maintenance	13
◆ Long storage and disposal	14
• When not using this unit for long term / When disposing	14
◆ In the Event of Failure	15
◆ After Service and Warranty	16
◆ Specification	17
◆ Wiring Diagram	18
◆ Replacement Parts Table	21
◆ Reference	22
• List of Dangerous Substances	22

Explanation

MEANING OF ILLUSTRATED SYMBOLS

Illustrated Symbols

Various symbols are used in this safety manual in order to use the unit without danger of injury and damage of the unit. A list of problems caused by ignoring the warnings and improper handling is divided as shown below. Be sure that you understand the warnings and cautions in this manual before operating the unit.

 **WARNING!** If the warning is ignored, there is the danger of a problem that may cause a serious accident or even fatality.

 **CAUTION!** If the caution is ignored, there is the danger of a problem that may cause injury/damage to property or the unit itself.

Meaning of Symbols



This symbol indicates items that urge the warning (including the caution). A detailed warning message is shown adjacent to the symbol.



This symbol indicates items that are strictly prohibited. A detailed message is shown adjacent to the symbol with specific actions not to perform.



This symbol indicates items that should be always performed. A detailed message with instructions is shown adjacent to the symbol.

Cautions in Using with Safety

Table of Illustrated Symbols

Warning



Warning,
generally

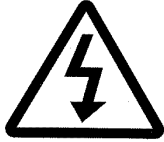

Warning,
high voltage



Warning,
high temperature



Warning,
drive train

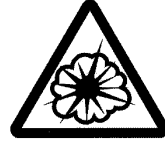

Warning,
explosive

Caution



Caution,
generally



Caution,
electrical shock



Caution,
scald



Caution,
no road heating



Caution,
not to drench



Caution,
water only



Caution,
deadly poison

Prohibit



Prohibit,
generally



Prohibit,
inflammable



Prohibit,
to disassemble



Prohibit,
to touch

Compulsion



Compulsion,
generally



Compulsion,
connect to the
grounding
terminal



Compulsion,
install on a flat
surface



Compulsion,
disconnect the
power plug



Compulsion,
periodical
inspection

Cautions in Using with Safety

Fundamental Matters of “WARNING!” and “CAUTION!”

WARNING!

Do not use this unit in an area where there is flammable or explosive gas

Never use this unit in an area where there is flammable or explosive gas. This unit is not explosion-proof. An arc may be generated when the power switch is turned on or off, and fire/explosion may result. (Refer to page22 “List of Dangerous Substances”.)

Always ground this unit

Always ground this unit on the power equipment side in order to avoid electrical shock due to a power surge.

If a problem occurs

If smoke or strange odor should come out of this unit for some reason, turn off the power key right away, and then turn off the circuit breaker and the main power. Immediately contact a service technician for inspection. If this procedure is not followed, fire or electrical shock may result. Never perform repair work yourself, since it is dangerous and not recommended.

Do not use the power cord if it is bundled or tangled

Do not use the power cord if it is bundled or tangled. If it is used in this manner, it can overheat and fire may be caused.

Do not process, bend, wring, or stretch the power cord forcibly

Do not process, bend, wring, or stretch the power cord forcibly. Fire or electrical shock may result.

Pay special attention to the measure for flammability and handling of flammable solvent

Leaving at the temperature higher than the room temperature may vaporize the flammable material (ethanol, etc.). There might be the case that some flammable liquid might be vaporized at the temperature lower than the room temperature. The result of such careless handling could cause the fire or explosion. Do provide the vaporization with enough during the operation.

Do not disassemble or modify this unit

Do not disassemble or modify this unit. Fire or electrical shock or failure may be caused.

Cautions in Using with Safety

Fundamental Matters of “WARNING!” and “CAUTION!”

CAUTION!

During a thunder storm

During a thunderstorm, turn off the power key immediately, then turn off the circuit breaker and the main power. If this procedure is not followed, fire or electrical shock may be caused.

Do not touch the liquid in the cooling coil and trap bath

Since the liquid in the cooling coil and trap bath is stayed with low temperature, never touch it so as to preventing from getting frostbite on your hands.

Do not touch the cooling fin with bare hands

Do not touch the cooling fin with bare hands during maintenance, for the edge of the cooling fin is too sharp to cut your hand.

Requirements for Installation

WARNING!

1. Always ground this unit



- Connect the power plug to a receptacle with grounding connectors.
- Do not forget to ground this unit, to protect you and the unit from electrical shock in case of power surge. Choose a receptacle with grounding connectors as often as possible.
- Do not connect the grounding wire to a gas pipe, or by means of a lightning rod or telephone line. A fire or electrical shock will occur.
- The CF1100 type uses a triple-phase 200V power source. Be sure to connect this model to the specific power switchboard or receptacle for 200V.

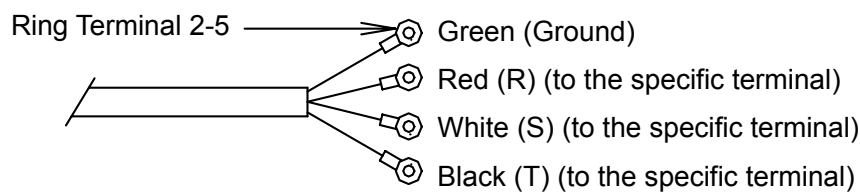

2. Choose a proper place for installation



- Do not install this unit in a place where:
 - ◆ Rough or dirty surface.
 - ◆ Flammable gas or corrosive gas is generated.
 - ◆ Ambient temperature below 5°C or above 35°C.
 - ◆ Ambient temperature fluctuates violently.
 - ◆ There is direct sunlight.
 - ◆ There is excessive humidity and dust.
 - ◆ There is a constant vibration.



- Install this unit on a stable place with the space as shown below.

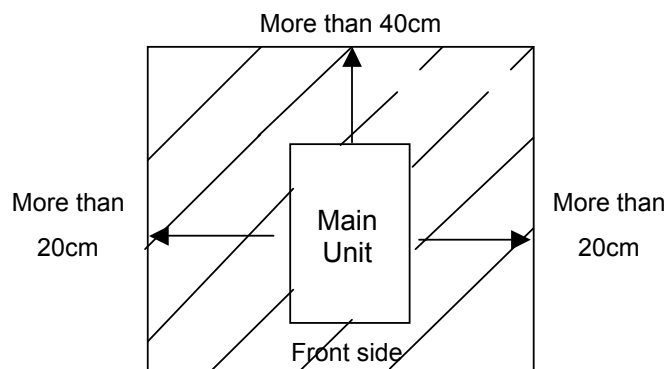

Requirements for Installation

3. Do not use this unit in an area where there is flammable or explosive gas



- Never use this unit in an area where there is flammable or explosive gas. This unit is not explosion-proof. An arc may be generated when the power switch is turned ON or OFF, and fire/explosion may result.
- To know about flammable or explosive gas refer to page22 “List of Dangerous Substances”.

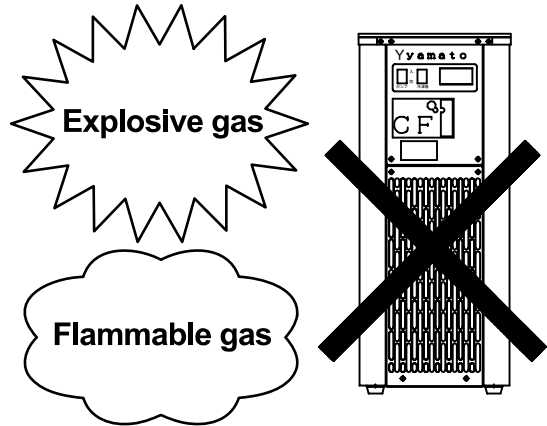

4. Do not modify



- Modification of this unit is strictly prohibited. This could cause a failure.

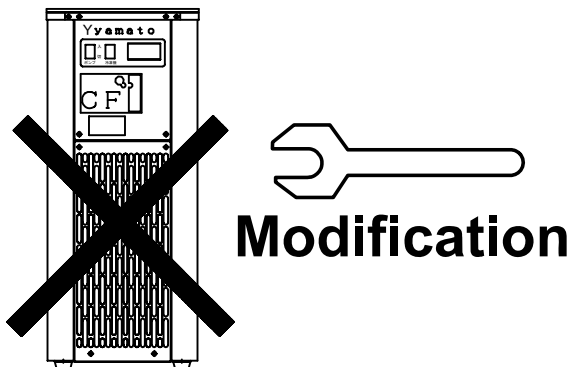

5. Do not topple or tilt this unit



- Set this unit to the flattest place. This unit incorporates the refrigerator. Do not topple or tilt it.

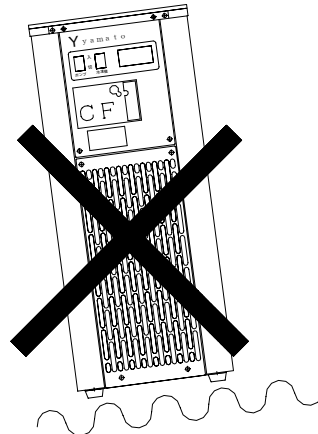

CAUTION!

6. Use specified receptacle for power source



- Choose a correct power distribution board or receptacle that meets the unit's rated electric capacity.

Electric capacity: CF300: 100V AC, 50/60Hz, 6A
CF701: 100V AC, 50/60Hz, 10A
CF1100: 200V AC (triple phase), 50/60Hz, 6A

NOTE)



Starburst connection with a branching receptacle or extended wiring with a cord reel lowers electrical power voltage, which may cause the degradation of refrigeration capability.

Requirements for Installation

7. Before/after installing

- 
 - It may cause injury to a person if this unit falls down or moves by the earthquake and the impact, etc.. To prevent, take measures that the unit cannot fall down, and not install to busy place.
 - Though this unit has the air-cooled refrigerator, the device exhausts the heat. Do provide the vaporization with enough so as not to raise the ambient temperature caused by the exhaust of the heat, or install this unit with its air controlled completely. If the ambient temperature becomes high, the operation efficiency becomes worse, and could cause the malfunction of the device by high temperature and humidity.

8. Handling of power code



- 
 - Do not entangle the power cord. This will cause overheating and possibly a fire.
 - Do not bend or twist the power cord, or apply excessive tension to it. This may cause a fire and electrical shock.
 - Do not lay the power cord under a desk or chair, and do not allow it to be pinched in order to prevent it from being damaged and to avoid a fire or electrical shock.
 - Keep the power cord away from any heating equipment such as a room heater. The cord's insulation may melt and cause a fire or electrical shock.
- 
 - If the power cord becomes damaged (wiring exposed, breakage, etc.), immediately turn off the power at the rear of this unit and shut off the main supply power. Then contact your nearest dealer for replacement of the power cord. Leaving it may cause a fire or electrical shock.
 - Connect the power plug to the receptacle which is supplied appropriate power and voltage.

9. Before/after installing

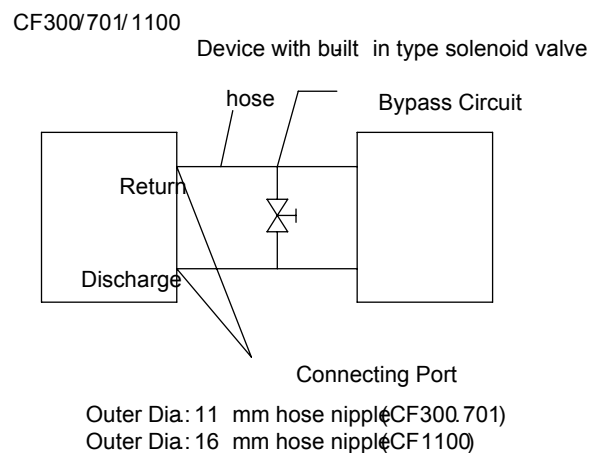
- 
 - Connect the circulation port of the main body to the coolant device securely so as not to leak cooling liquid.
 - Closing the circulation path with the solenoid valve or throttle valve might cause the malfunction of the pump such as water leakage.
 - Please open the stop valve of a CF701 discharge and the return at the time of the pump driving by all means.
 - Pay attention to the over-throttle. Throttle the path with the flow rate of the device kept 1.5 liter per min. or more.
 - In case that there are solenoid valve on the device to be performed the circulation cooling, or in case that the flow rate of the device is lower than the 1.5 liter per min., set the bypass circuit between the main device and peripheral devices.



10. Apply the 40% ethanol solution as the cooling liquid (heating medium)

- 
 - Adjust the water solution with its alcoholic density be 40% (Vol%) or more so as not to freeze the cooling liquid. Note that the non-frozen liquid and ethylene glycol solution specified in JIS K2234 have large argillaceous and specific gravity. These characters cause the overload to the pump, and reduce the efficiency of the thermal conductivity. Therefore, do not apply these solutions as the cooling liquid. Besides, the cooling liquid including flon has large specific gravity, and cause the overload to the pump, and finally cause the corrosion to the cooling coil. Never to apply these cooling liquids.
- 

Description and Function of Each Part

Main Unit and Control panel

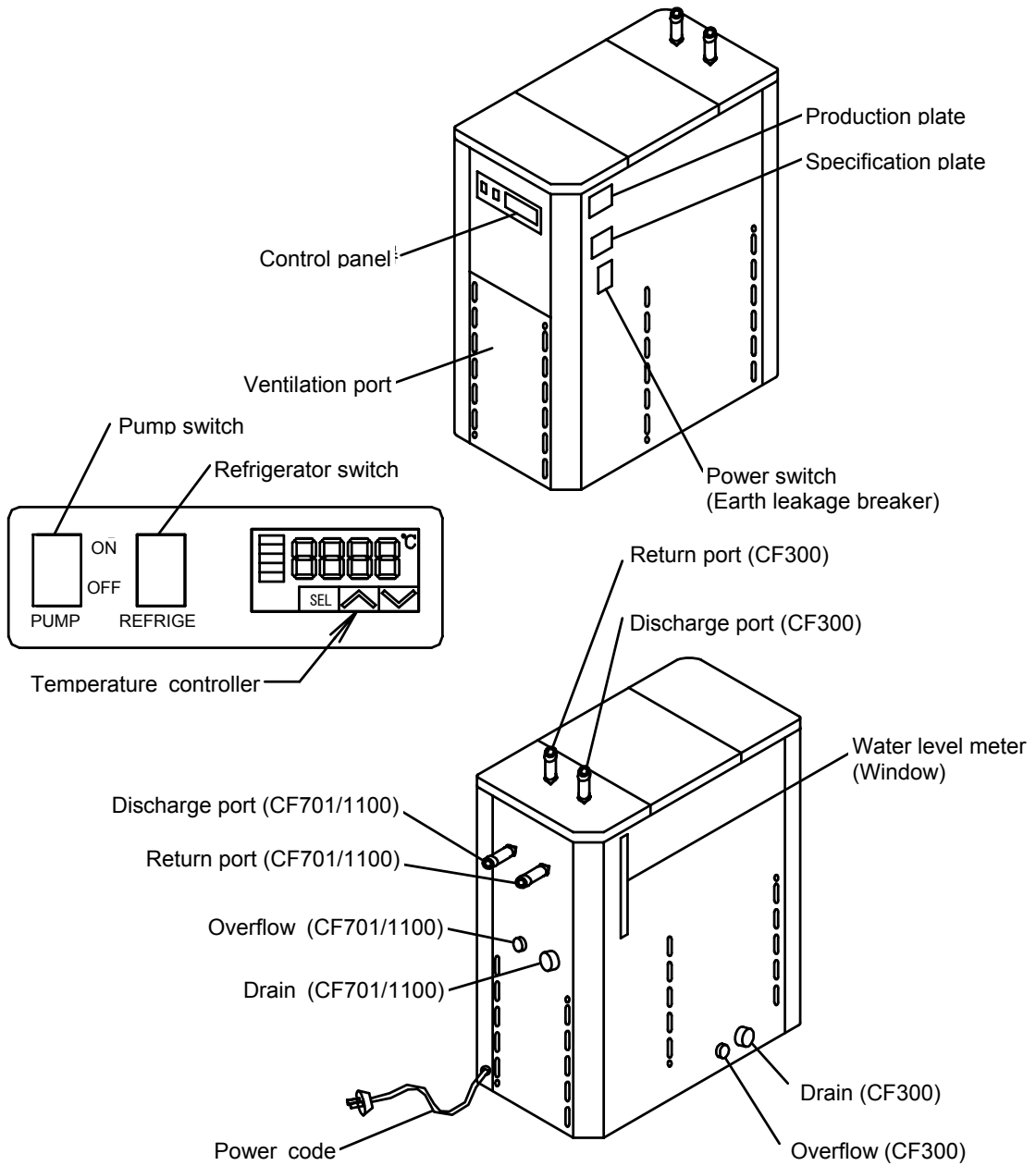

CAUTION) CF701 is with a stop valve

Part Name	Function
Power switch (Earth Leakage Breaker) :	This is the power switch Turns ON/OFF the main power.
Temperature controller :	Controls the temperature of cooling liquid in the bath. (Range: -20 to 30°C)
Refrigerator switch :	Turns ON/OFF the refrigerator.
Pump switch :	Turns ON/OFF the circulation pump.

1. Unlock the stopper of the caster.

(Only for CF701/1100)
 Pulling up the lever of the stopper for caster releases the lock.
 (Only the two casters in front of the unit are attached the stopped.)
2. Move the device to the place to be installed.
 - ❖ If there is a step on the floor, the too strong impact is given to the caster, and could give the damage. In that case, move the device by lifting at the step.
3. When the installation place is determined, pull down the lever of the stopper for caster, and lock them.
4. Drain/Overflow Cap Check.
 - (CF300)
 Check that the drain port and the overflow port are sealed with the cap.
 - (CF701/1100)
 Check that the drain valve is set at the "CLOSE" position.

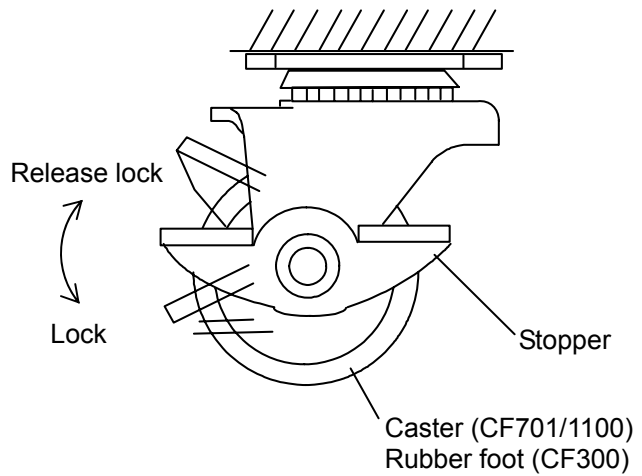

CF701/1100

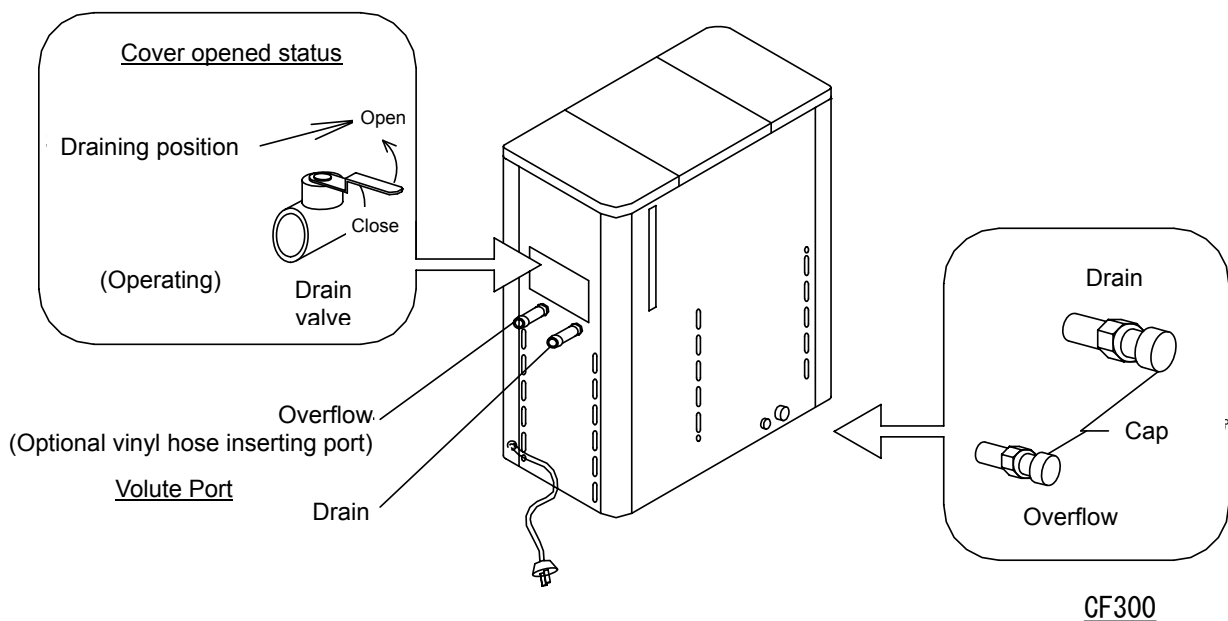

5. Power Plug Connection

- Check the earth leakage breaker, the refrigerator switch and the pump switch are turned "OFF", and plug the power cord in the receptacle.

6. Insert the cooling liquid into the bath

- Remove the cover of the bath, and insert the 40% ethanol solution into the bath with its cooling coil hidden. When supplying the liquid, remove the cap (CF300) of the overflow on the left side surface of the bath without fail, and prepare the pan for the bath. (The CF701/1100 overflow has the volute port.)
- With this status, turn on the pump switch, and circulate the liquid. At this time, check that the liquid is circulated with no abnormal noise. There would be the case that the liquid is not circulated because of the remained air in the bath. Turn on and off the pump switch for several times for evacuating the remained air. After completing the evacuation of the remained air, the liquid might be circulated. Even though the liquid is not circulated yet, turn off the power of the refrigerator and pump switch immediately, check the status of the relevant devices referring to Page 15 "In the Event of Failure...". (Keeping the operation of the device without circulating the liquid could cause the malfunction of the circulation pump.)
- After stabilizing the liquid circulation, supply the liquid up to the position where the cooling coil is hidden with the liquid. Note that the water gauge on the left side surface of the main device indicates the water position in the bath. Check that the liquid is filled up to the appropriate position.
- After supplying the liquid, turn OFF the power.
- Cover the bath.

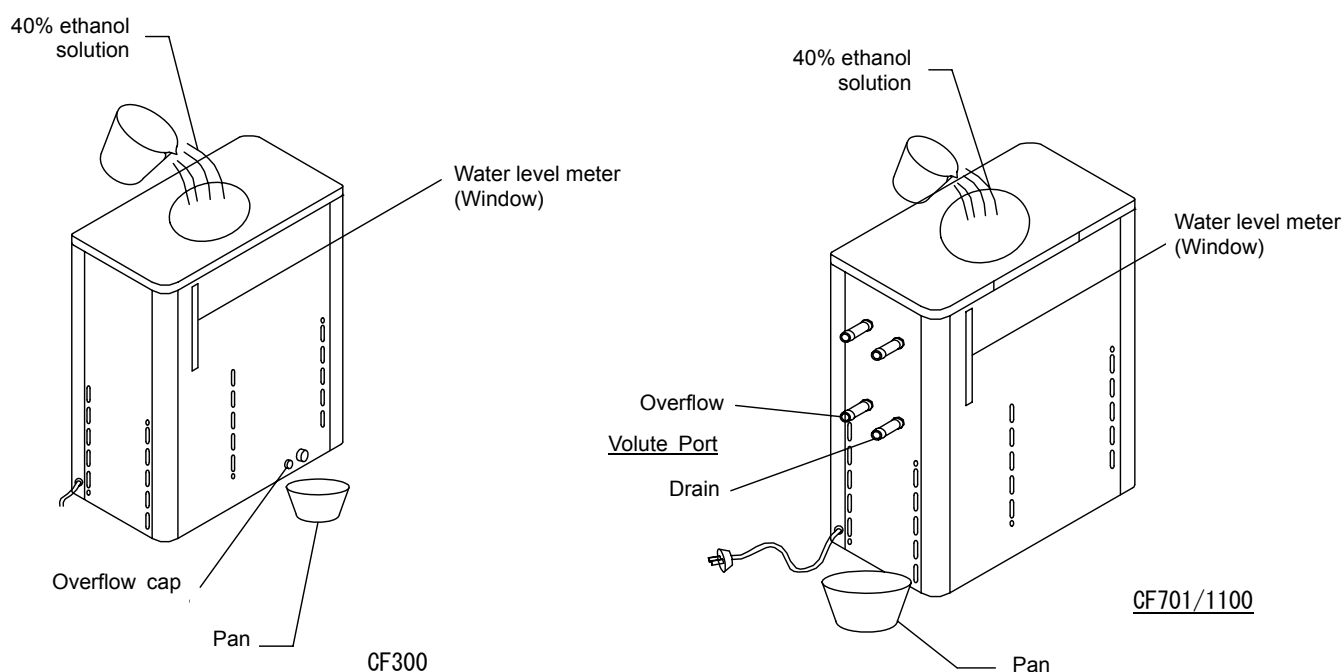

Procedure of Operation

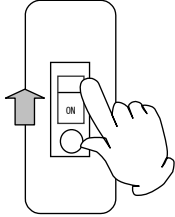
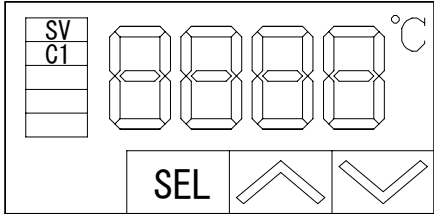
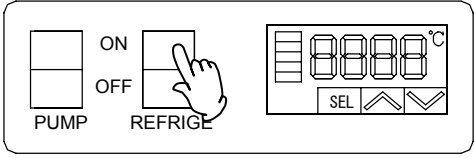
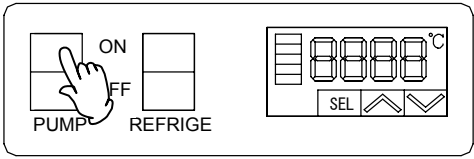
<p>1. Turn "ON" the earth leakage breaker.</p>	
<p>2. Set the temperature. Set the temperature to be applied with the "SEL" key. Pressing the "SEL" key lights on the SV indicating lamp. Set the temperature with "▲,▼" keys, and press the "SEL" key again after checking the setting status of the temperature.</p>	
<p>3. Turning on switch of the refrigerator. After checking the C1 lamp of the temperature controller (control output 1) is turned ON, turn on the switch of the refrigerator. The device starts operation by the actuation of the time after passing about 3 minutes.</p> <p>❖ Note: The lighting on and off status of the "C1" lamp of the temperature controller indicates the performance status of the output contacting point. Since the actual control temperature is controlled by the "ON" and "OFF" of the refrigerator, the time delay between the "C1" lamp motion of the temperature controller and "ON" "OFF" timing of the refrigerator might be occurred. This time delay might be caused by the pre-setting of the 3-minute delay circuit for preventing from the refrigerator malfunction.</p>	
<p>4. Turning on the pump switch. Check that the hose is connected between the circulation port of the main device and cooling device, and that the circulation liquid is filled into the water bath. Then turn on the pump switch. Please open the stop valve of a CF701 discharge and the return at the time of the pump driving by all means.</p>	
<p>5. End of the operation. Turn off the pump, refrigerator switch, and main power switch.</p>	

WARNING!

If a problem occurs

-  If smoke or strange odor should come out of this unit for some reason, turn off the power key right away, and then turn off the breaker and the main power. Immediately contact a service technician for inspection. If this procedure is not followed, fire or electrical shock may result. Never perform repair work yourself, since it is dangerous and not recommended.

Measure for flammability and handling of flammable solvent

-  This unit is not designed as the explosion-proof construction. Pay special attention to the handling of the sample to be handled with this unit on the consumption with the explosive material, flammable material, and similar ones. The flammable material may be vaporized by leaving it at the temperature higher than room temperature, and could cause the fire or explosion. When handling such material, provide ventilation with enough before the operation. (Refer to page22 "List of Dangerous Substances".)

CAUTION!

Water bath capacity

-  The water bath capacities of the CF300/701/1100 type devices are approx. 3 liters, 14 liters, and 37 liters. If the liquid is supplied over these capacities, the leakage of the liquid might be occurred.

Do not step on this unit

-  Do not step on this unit. It will cause injury if this unit fall down or break.

Do not put anything on this unit

-  Do not put anything on this unit. It will cause injury if fall.



During a thunder storm

-  During a thunderstorm, turn off the power key immediately, then turn off the circuit breaker and the main power. If this procedure is not followed, fire or electrical shock may be caused.

Countermeasure for stop operation during night or long-term stop

-  In case of stopping operation during night or long-term, toggle the power switch to "OFF".

Circulation pump protection

-  • Never operate the circulation pump with no liquid. Failure to do so could cause the malfunction of the pump.
- If any obstacles are included in the cooling liquid, this obstacle might be caused the breakage of the pump.
-  • In case that the solenoid valve and throttle valve are attached to the circulation path, do not leave the valve in closed or too much throttled statuses for preventing from the pump damage.
- Always keep the flow rate of the circulation liquid at least 1.5 liter per min.

Daily Inspection and Maintenance

WARNING!

- Disconnect the power cable from the power source when doing an inspection or maintenance unless needed.
- Perform the daily inspection and maintenance after returning the temperature of this unit to the normal one.
- Do not disassemble this unit.
- Do not touch the cooling fin with bare hands.

CAUTION!

- Use a well-drained soft cloth to wipe dirt on this unit. Do not use benzene, thinner or cleanser for wiping. Do not scrub this unit. Deformation, deterioration or color change may result in.

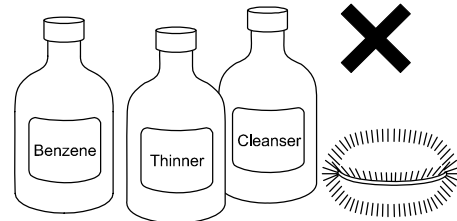

Monthly maintenance

- Check the earth leakage breaker function.
 1. Connect the power cord.
 2. Turn the breaker on.
 3. Push the red test switch by a ballpoint pen etc.
 4. If there is no problem, the earth leakage breaker will be turned off.

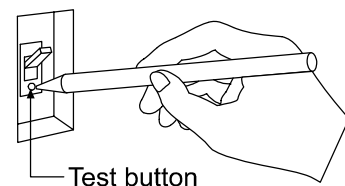

Cleaning of cooling fin

- Clogging of the cooling fin could cause the deterioration of the cooling performance, and also cause the malfunction of the refrigerator. The clogged status differs depending on the surrounding condition or operation time. Clean the cooling fin periodically.
- ❖ Loosen the mounting screws (4 screws) of the ventilation port cover, remove the cover of the ventilation port, and remove the dust attached to the surface of the cover using the vacuum cleaner.
- ❖ After cleaning the cooling fin, attach it in inverse procedure.

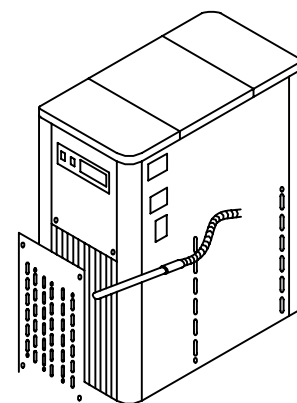

 Take care not to crush the fin during cleaning.

For any questions, contact the dealer who you purchased this unit from, or the nearest sales division in our company.

When not using this unit for long term / When disposing

CAUTION!

When not using this unit for long term...

- Turn off the power and disconnect the power cord.

WARNING!

When disposing...

- Keep out of reach of children.
- Treat as large trash.

Environmental protection should be considered

We request you to disassemble this unit as possible and recycle the reusable parts considering to the environmental protection. The feature components of this unit and materials used are listed below.

Component Name	Material
Parts of Main Unit	
Casing	Bonderizing steel plate baked with melamine resin coating
Inner bath	Stainless steel
Cover	Stainless steel, Resin
Production plates	Polyester (PET) resin film
Corner	Alkylbenzenesulfied (ABS) resin
Caster (CF701/1100)	Iron, Steel
Rubber foot (CF300)	Synthetic rubber
Electrical Parts	
Switches, Relays	Composites with resin and others
Power cord & wiring materials and others	Composites with synthetic rubber, copper, nickel and others
Fan motor	Aluminum, Other synthetic
Pump	Composites with iron, copper, resin, ceramic and others
Parts of Refrigeration System	
Compressor	Composites with iron, copper and others
Condenser	Iron, Copper, Aluminum
Cooling device	Nickel plated copper
Piping parts	Composites with copper and others
Parts of Water Path	
Drain, overflow and inner piping	Silicon rubber
Connecting parts	Resin
Insulating hose	Polyurethane sponge
Sealed Cooling Medium for Refrigerator	
Cooling medium	R404A Ask the specialist for the dealing of cooling medium.

Trouble Shooting

Condition	Possible Causes
Refrigerator does not start when turning on the power switch.	<ul style="list-style-type: none"> • Power plug is not connected to the receptacle correctly. • Power failure. • Earth leakage breaker is turned to "OFF"
Not fallen the temperature.	<ul style="list-style-type: none"> • The cooling fin is clogged. • The cooling liquid is overheated. • The ambient temperature is exceeding 30°C or 35°C. • The peripheral of the ventilating port is shut down.
Refrigerator cannot be restarted.	<ul style="list-style-type: none"> • The refrigerator is in overloaded. Turn off the power of the refrigerator immediately, keep the temperature, and turn on the power of the refrigerator after a while.
The liquid is not circulated.	<ul style="list-style-type: none"> • Is the circulation path is closed or throttled too narrow at any point? • Is the argillaceous or specific gravity of the cooling liquid appropriate?

Error Display

Error Sign	Cause	Remedy
UUUU	Sensor disconnection	Check the sensor connection.
FALR	Malfunction of the temperature controller	Stop operation. Turn off the power immediately,

In the case if the error other than listed above occurred, turn off the power switch and primary power source immediately. Contact the shop of your purchase or nearest Yamato Scientific Service Office.

In Case of Request for Repair

If the failure occurs, stop the operation, turn OFF the power switch, and unplug the power plug. Please contact the sales agency that this unit was purchased, or the Yamato Scientific's sales office.

< Check following items before contact >

- ◆ Model Name of Product
 - ◆ Production Number
 - ◆ Purchase Date
 - ◆ About Trouble (in detail as possible)
- } See the production plate attached to this unit.

Minimum Retention Period of Performance Parts for Repair

The minimum retention period of performance parts for repair of this unit is 7 years after discontinuance of this unit.

The "performance part for repair" is the part that is required to maintain this unit.

Model		CF300	CF701	CF1100	
Circulation system		Closed circulation			
Operational ambient temperature		5 to 35°C			
Performance	Temperature setting range	-20 to room temp		-10 to room temp	
	Refrigerator (AC100V 50Hz) (kcal/h·W·liquid temp)	385kcal·450W · at10°C	770kcal·900W · at10°C	2500kcal·2900W · at20°C	
		300kcal·350W · at0°C	600kcal·700W · at0°C	2100kcal·2440W · at10°C	
		220kcal·260W · at-10°C	410kcal·480W · at-10°C	-	
	Pump (*)	Max. flow rate	50Hz: Approx. 14L/min 60Hz: Approx. 15.5L/min (discharge pressure: 0kpa)	50Hz: Approx. 22L/min 60Hz: Approx. 22L/min (discharge pressure: 0kpa)	50Hz: Approx. 40L/min 60Hz: Approx. 43L/min (discharge pressure: 0kpa)
		Max. discharge pressure	50Hz: Approx. 41kpa 60Hz: Approx. 55kpa (flow rate: 0L/min)	50Hz: Approx. 98kpa 60Hz: Approx. 132kpa (flow rate: 0L/min)	50Hz: Approx. 140kpa 60Hz: Approx. 199kpa (flow rate: 0L/min)
Rising range		4.2m/5.6m	10m/13.5m	14.3m/20.3m	
Configuration	Temperature control system	Refrigerator ON/OFF			
	Temperature sensor	T thermo couple (with SUS protection tube)			
	Temperature setting /display system	Digital setting/display			
	Refrigerator	Air cooling, 350W	Air cooling, 600W	Air cooling, 1100W	
	Cooling medium	R404a			
	Cooling coil	Nickel plated copper		Copper	
	External circulation nozzle	Outer diameter: 11mm (both discharge and return) with hose nipple		Outer diameter: 16mm (RC1/2) (both discharge and return) with hose nipple	
	Circulation pump	Magnetic pump 10/15W	Magnetic pump 65/65W	Magnetic pump 180/216W	
	Bath	Material	SUS304		
		Dimensions	φ 174×170mm	φ 300×235mm	φ 370×400mm
Capacity	Approx. 4L (liquid quantity: 3L)	Approx. 16L (liquid quantity: 14L)	Approx. 43L (liquid quantity: 37L)		
Safety devices		Electric leakage breaker, Overload relay keeping circuit for refrigerator, Pump thermal protector, Delay timer for refrigerator protection			
Other functions		Overflow, Drainage, Water level meter			
		-	Aspirator unit attachable	Reverse phase protection relay	
Standards	External dimensions (W×D×H mm)	210×400×500	350×480×840	420×650×1200	
	Weight	Approx. 27Kg	Approx. 54Kg	Approx. 95Kg	
	Power supply	100V AC, 50/60Hz, 4.5A	100V AC, 50/60Hz, 10A	200V AC, 50/60Hz, triple phase, 6A	
Accessories		Instruction manual, Circulation hose (1.5m)×2, Wire clamp ×2			
		Cover	Cover, Vinyl hose	Vinyl hose	

* At room temperature: 23°C, heat medium: water.

CF300

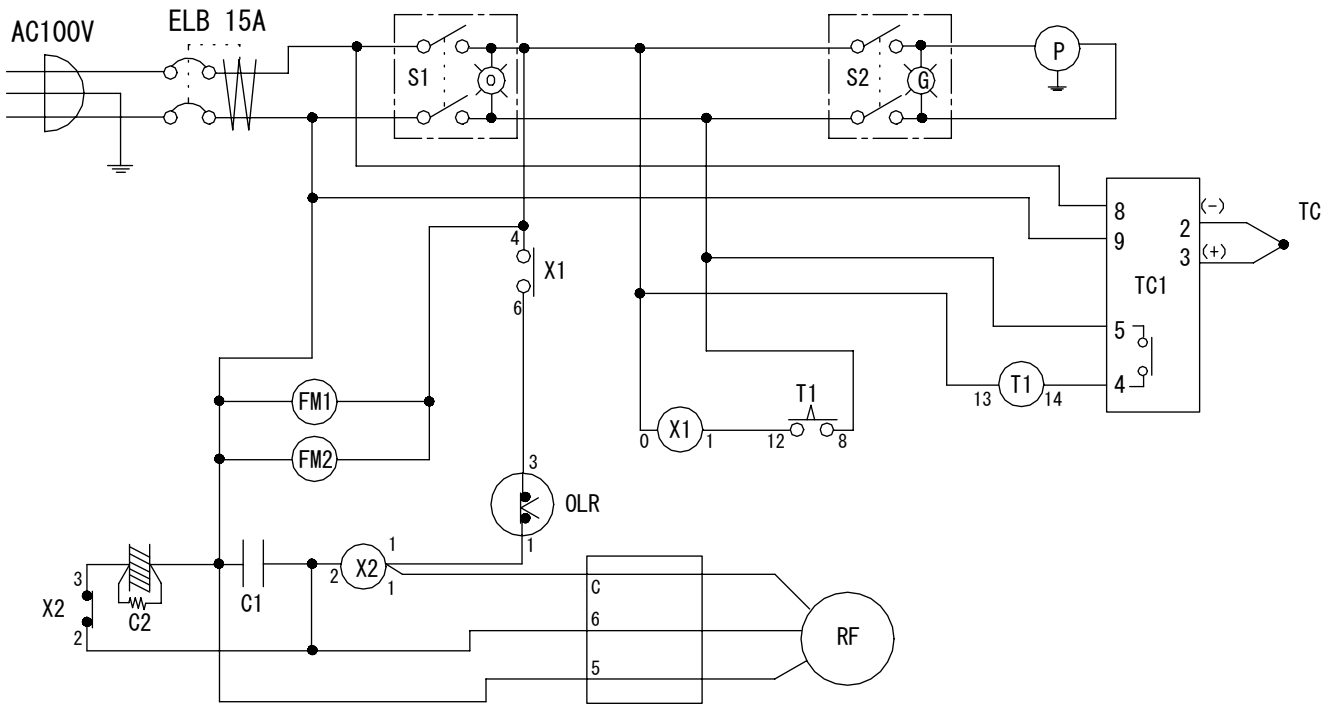

Symbol	Part name	Symbol	Part name
ELB	Earth leakage breaker	T1	Delay timer relay
TC1	Temperature controller	C1	Operation condenser
S1	Refrigerator switch	C2	Start condenser
S2	Pump switch	FM1/FM2	Fan motor
X1	Relay	RF	Refrigerator
X2	Start relay	P	Pump
TC	Temperature sensor	OLR	Overload relay

CF701

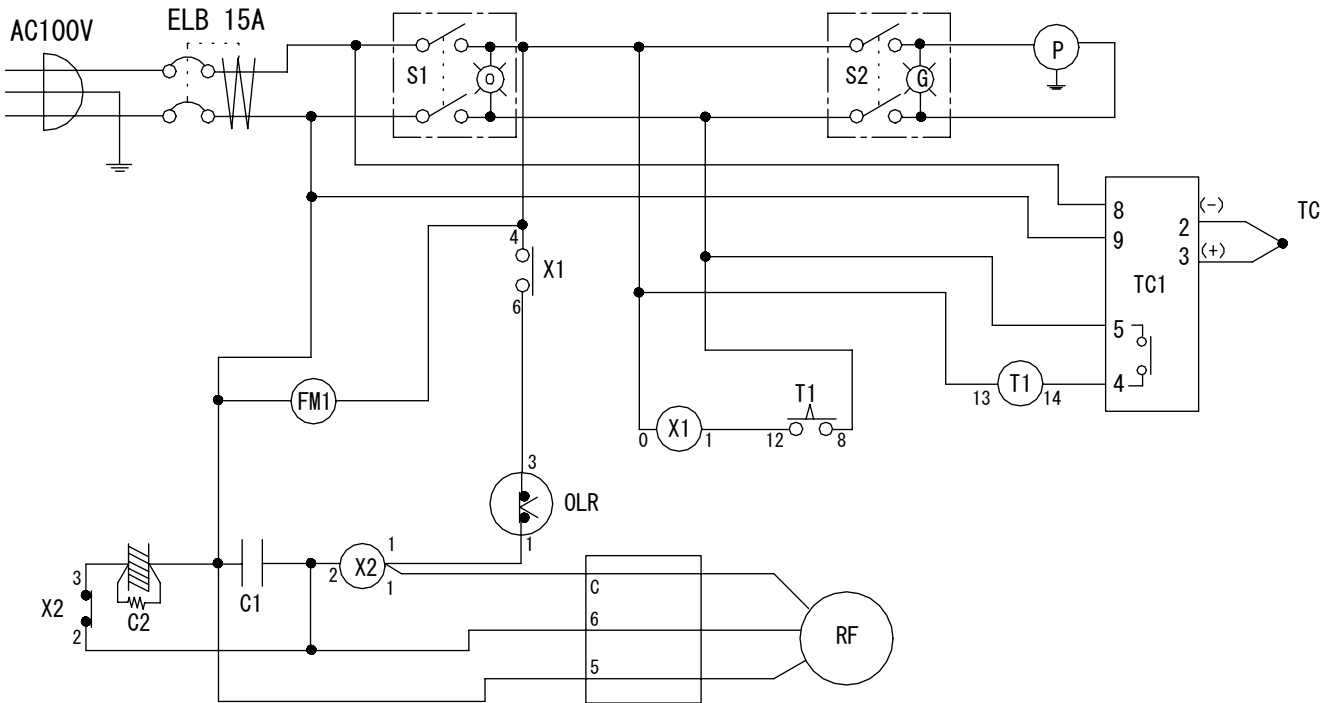

Symbol	Part name	Symbol	Part name
ELB	Earth leakage breaker	T1	Delay timer relay
TC1	Temperature controller	C1	Operation condenser
S1	Refrigerator switch	C2	Start condenser
S2	Pump switch	FM1	Fan motor
X1	Relay	RF	Refrigerator
X2	Start relay	P	Pump
TC	Temperature sensor	OLR	Overload relay
TM	Terminal block		

CF1100

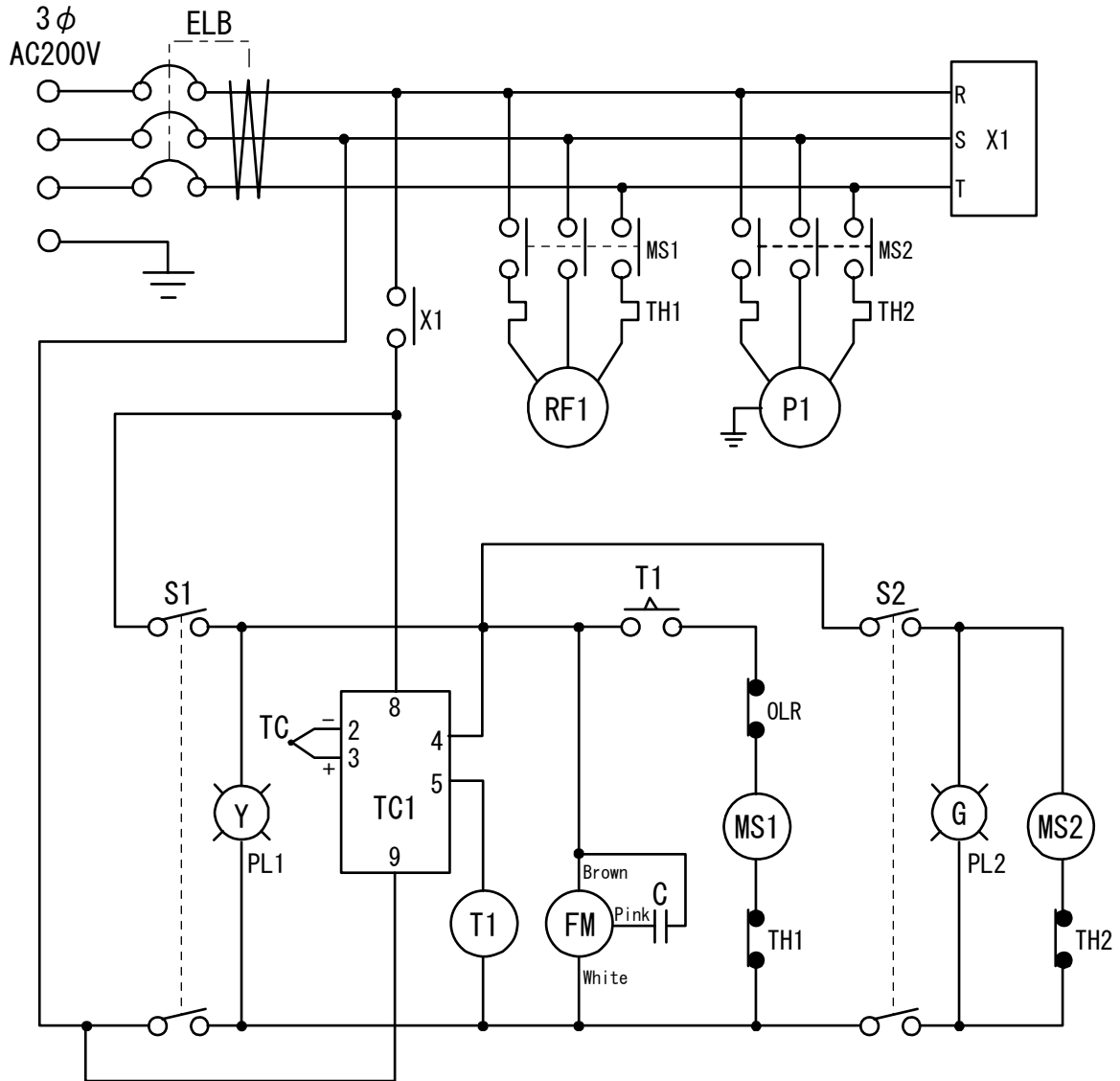

Symbol	Part name	Symbol	Part name
ELB	Earth leakage breaker	MS1	Refrigerator solenoid valve
TC1	Temperature controller	MS2	Pump solenoid valve
S1	Refrigerator switch	TH1	Refrigerator thermal relay
S2	Pump switch	TH2	Pump thermal relay
X1	Relay	FM	Fan motor
T1	Delay timer relay	RF1	Refrigerator
TC	Temperature sensor	P1	Pump
		OLR	Overload relay

Replacement Parts Table

Common parts

Part Name	Code No.	Specification	Manufacturer
Temperature sensor	1-16-003-0055	φ3.2×30mm	Nihon Densoku
Refrigerator switch	2-55-000-0017	CW-SB21NYKZYEF	Nihon Kaiheiki
Pump switch	2-55-000-0011	CW-SB21NMKZMEF	Nihon Kaiheiki
Temperature controller	5-17-000-0006	PXR3TAY1-0Y000	Fuji Denki
Socket	2-55-000-0016	TP88X1	Fuji Denki

CF300

Part Name	Code No.	Specification	Manufacturer
Refrigerator unit	3-01-006-0005	C-2SN350LPR	Sanyo Denki
Earth leakage breaker	LT00029774	NV-L22GR 15A	Mitsubishi
Delay timer relay	2-55-000-0014	ST7P-2 (MS7P2-A11N)	Fuji Denki
Relay	2-05-000-0056	G7L-1A-TUB	Omron
Fan motor	2-15-000-0010	UF-12A10	Full tech
Pump	2-15-009-0006	PMD-121B7B	Sanyo Denki

CF701

Part Name	Code No.	Specification	Manufacturer
Refrigerator unit	3-01-006-0012	C-RHN60LOA	Sanyo Denki
Earth leakage breaker	LT00029774	NV-L22GR 15A	Mitsubishi
Delay timer relay	2-55-000-0014	ST7P-2 (MS7P2-A11N)	Fuji Denki
Electromagnetic Contact	LT00032906	FC-0ST 1a 100V	Fuji Denki
Fan motor	3-01-000-0014	SE4-D11LP	Sanwa Techno
Pump	2-15-008-0011	MD-40RZ-N	Iwaki

CF1100

Part Name	Code No.	Specification	Manufacturer
Refrigerator unit	3-01-006-0013	C-RHN113E3A	Sanyo Denki
Earth leakage breaker	2-06-000-0026	EG33F 15A 30mA	Fuji Denki
Delay timer relay	2-55-000-0015	ST7P-2 (MS7P2-A11N)	Fuji Denki
Fan motor	3-01-006-0015	SV4-21X3P	Sanwa Techno
Refrigerator solenoid valve	2-05-000-0058	FW-0 4A AC200V 1a	Fuji Denki
Pump solenoid valve	2-05-000-0057	FW-0 3A AC200V 1a	Fuji Denki
Pump	2-15-008-0012	MD-70RZ	Iwaki

List of Dangerous Substances



Never use explosive substances, flammable substances and substances that include explosive or flammable ingredients in this unit.

EXPLOSIVE

EXPLOSIVE:	Ethylene glycol dinitrate (nitro glycol), Glycerin trinitrate (nitroglycerine), Cellulose nitrate (nitrocellulose), and other explosive nitrate esters
	Trinitrobenzene, Trinitrotoluene, Trinitrophenol (picric acid), and other explosive nitro compounds
	Acetyl hidroperoxide (peracetic acid), Methyl ethyl ketone peroxide, Benzyl peroxide, and other organic peroxides

FLAMMABLE

IGNITING:	Lithium (metal), Potassium (metal), Sodium (metal), Yellow phosphorus, Phosphorus sulfide, Red phosphorus, Celluloid compounds, Calcium carbide, Lime phosphate, Magnesium (powder), Aluminum (powder), Powder of metals other than magnesium and aluminum, Sodium hydrosulfite
OXIDIZING:	Potassium chlorate, Sodium chlorate, Ammonium chlorate, and other chlorate
	Potassium perchlorate, Sodium perchlorate, Ammonium perchlorate, and other perchlorate
	Potassium peroxide, Sodium peroxide, Barium peroxide, and other inorganic peroxide
	Potassium nitrate, Sodium nitrate, Ammonium nitrate, and other nitrate
	Sodium chlorite and other chlorites
	Calcium hypochlorite and other hypochlorites
INFLAMMABLE LIQUID:	Ethyl ether, Gasoline, Acetaldehyde, Propylene chloride, Carbon disulfide, and other flammable substances having a flash point of lower than -30°C
	Normal hexane, ethylene oxide, acetone, benzene, methyl ethyl ketone, and other flammable substances having a flash point of -30°C or higher but lower than 0°C
	Methanol, Ethanol, Xylene, Pentyl acetate (amyl acetate), and other flammable substances having a flash point of 0°C or higher but lower than 30°C
	Kerosene, Light oil (gas oil), Oil of turpentine, Isopentyl alcohol (isoamyl alcohol), Acetic acid, and other flammable substances having a flash point of 30°C or higher but lower than 65°C
FLAMMABLE GAS:	Hydrogen, Acetylene, Ethylene, Methane, Propane, Butane, and other flammable substances which assume a gaseous state at 15°C and 1 atm

(Source: Appendix Table 1 of Article 6 of the Industrial Safety and Health Order in Japan)

Responsibility

Please follow the instructions in this document when using this unit. Yamato Scientific has no responsibility for the accidents or breakdown of device if it is used with a failure to comply. Never conduct what this document forbids. Unexpected accidents or breakdown may result in.

Note

- ◆ The contents of this document may be changed in future without notice.
- ◆ Any books with missing pages or disorderly binding may be replaced.

Instruction Manual for
Neo-cool Circulator
Model CF300/701/1100

Fourth Edition Mar. 20, 2010
Revised Feb. 20, 2012

Yamato Scientific Co., Ltd.

2-1-6 Nihonbashi Honcho, Chuo-ku,
Tokyo, 103-8432, Japan

<http://www.yamato-net.co.jp>