



Cold Trap CA301

Instruction Manual

First Edition

- Thank you very much for purchasing this Yamato Cold Trap CA301.
- Please read the “Operating Instructions” and “Warranty” before operating this unit to assure proper operation. After reading these documents, be sure to store them securely together with the “Warranty” at a handy place for future reference.

 **Warning:**

Before operating the unit, be sure to read carefully and fully understand important warnings in the operating instructions.

Yamato Scientific Co., Ltd.

1. Safety precautions	1
Explanation of pictograms	1
List of symbols	2
Warnings & Cautions	3
2. Before Use	4
Cautions for installation	4
Installation procedures/precautions	8
3. Name and Functions of Parts	9
Main body	9
Details of each component	10
4. Operation Method	11
Operation method	11
Operation method	12
5. Cautions for Handling	14
6. Maintenance	16
Daily inspection/maintenance	16
When the unit is not to be used for a long time or when disposing	17
When the unit is not to be used for a long time or when disposing	17
Requests in case of disposal	17
8. Troubleshooting Guide	18
Check list	18
9. After sales service and warranty	19
When requesting a repair	19
10. Specifications	20
11. Connection Diagram	21
Connection diagram	21
12. Replacement Parts List	22
13. List of dangerous materials	23
14. Standard installation manual	24

1. Safety precautions

Explanation of pictograms

About pictograms

A variety of pictograms are indicated in this operating instruction and on products for safe operation. Possible results from improper operation ignoring them are as follows.

Be sure to fully understand the descriptions below before proceeding to the text.

 **Warning** Indicates a situation which may result in death or serious injury (Note 1.)

 **Caution** Indicates a situation which may result in minor injury (Note 2) and property damages (Note 3.)

(Note 1) Serious injury means a wound, an electrical shock, a bone fracture or intoxication that may leave after effects or require hospitalization or outpatient visits for a long time.

(Note 2) Minor injury means a wound or an electrical shock that does not require hospitalization or outpatient visits for a long time.

(Note 3) Property damage means damage to facilities, devices and buildings or other properties.

Meanings of pictograms

 This pictogram indicates a matter that encourages the user to adhere to warning ("caution" included).
Specific description of warning is indicated near this pictogram.

 This pictogram indicates prohibitions
Specific prohibition is indicated near this pictogram.

 This pictogram indicates matters that the user must perform
Specific instruction is indicated near this pictogram.

1.Safety precautions

List of symbols

Warning



General warnings



Danger!: High voltage



Danger!: High temperature



Danger!: Moving part



Danger!: Hazard of explosion

Caution



General cautions



Electrical shock!



Burning!



Caution for no liquid heating!



Caution for water leak!



For water only



Poisonous material

Prohibitions



General bans



Fire ban



Do not disassemble



Do not touch

Compulsions



General compulsions



Connect ground wire



Install levelly



Pull out the power plug



Regular inspection

1. Safety precautions

Warnings & Cautions

Warning



Never operate the unit in an atmosphere containing flammable or explosive gas

Never operate the unit in an atmosphere containing flammable or explosive gas. Otherwise, an explosion or a fire may result since the unit is not explosion-proof. See section “13. List of dangerous materials” on page 23.



Be sure to connect the ground wire.

Be sure to connect the ground wire correctly. Otherwise, electrical leak may result and cause an electrical shock or a fire.



Ban on operation when an abnormality occurs

When a smoke or an unusual odor is seen or sensed, immediately turn the ELB on the main unit off and pull out the power plug. A fire or an electrical shock may result.



Never use electrical power cords bundled.

When these are used bundled, they might overheat causing a fire.



Take care not to damage electrical power cords.

Avoid tightly bend, pull with a strong force or twist to prevent electrical power cords from damaging. A fire or an electrical shock may result.



Ensure sufficient ventilation when using flammable and combustible solutions.

If left at the room temperature (or below for certain solutions), flammable and combustible solutions (ethanol, etc.) may be vaporized and thus ignited and exploded by any ignition source (switch, etc.).



Never try to disassemble or alter the unit.

Never try to disassemble or alter the unit. A malfunction, a fire or an electrical shock may result.



Caution



When a thunder is heard.

When a thunder is heard, turn the main power off immediately. A malfunction, fire or an electrical shock may result.



Keep hands away from the condensate of the cooling coil and trap tank.

Condensate in the cooling coil or trap tank becomes cold during operation and for a certain period of time after operation. If you touch it, you will suffer frost bite. Never touch the condensate.



Do not touch the condenser fin with bare hands.

Never touch the condenser fin with bare hands during maintenance. The fin has sharp edge and may cut hands.

2.Before Use

Cautions for installation

Warning

1. Take care to select an appropriate installation site.



Avoid installing the unit, above all, in places listed below:

- Uneven or dirty floor
- Where floor is not level.
- Where temperature may change widely.
- Where humidity is high.
- Where subject to direct sunlight.
- Place with unstable power supply.
- Where flammable gas or corrosive gas may exist.
- Where environmental temperature is 5°C or less or 35°C or over.
- Not well-ventilated place.
- Where vibrations are severe.
- Outdoor



Install this unit at a place with spaces shown below.

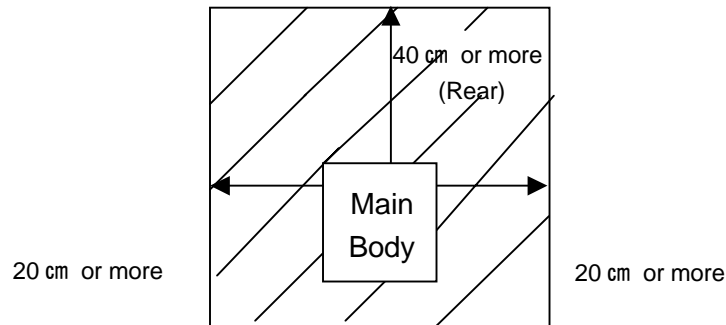

2. Installation



The unit might fall down or move by an earthquake or an impact resulting a personal injury. We recommend making safety measures such as to avoid installing the unit at a place other than busy places. This trap incorporates an air-cooling refrigerator, which produces waste heat. Use the trap in a well-ventilated or air conditioned place to prevent rising of the ambient temperature. Higher ambient temperature causes drop of operation efficiency. Moreover, the refrigerator is put into high-temperature high-pressure operation, resulting in failure.

3. Never operate the unit in an atmosphere containing flammable or explosive gas.



Never operate the unit in an atmosphere containing flammable or explosive gas. Since the unit is not explosion-proof, an arc is discharged when switching "ON" and "OFF" and during operation and a fire or an explosion may result.

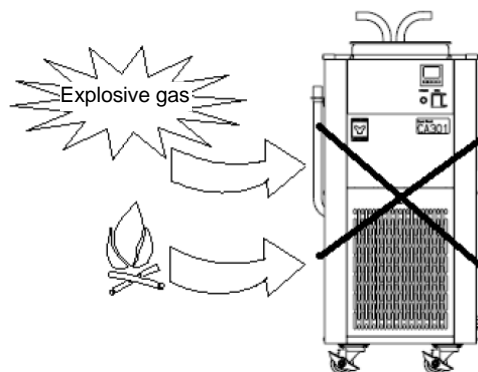

2. Before operating the unit

Precautions when installing the unit



4. Install the unit on a level surface.



Install the unit on a level surface. If the whole bottom surface of the unit does not contact the floor evenly, vibrations or noises may result. This might cause unexpected troubles or malfunctions.

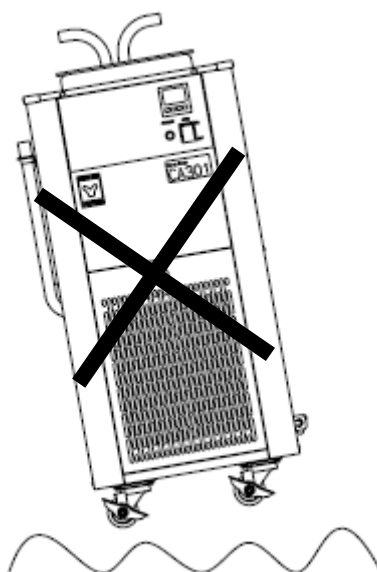

5. Do not install the main body in the tilted condition.



This product incorporates the refrigerator. Never transport the product with the main body lying on its side or in the tilted condition.

6. Secure sufficient ventilation for the unit.



Do not operate the unit when its front/side panels and vent holes are blocked. Internal temperature of the unit will rise degrading the performance and an accident, a malfunction or a fire may result.

7. Do not operate the unit at such a place that may subject to splash.



Do not operate the unit at such a place that may subject to splash. Liquid entering the inside may cause an accident, a malfunction, an electrical shock or a fire.

8. Never attempt reconstruction.



Never attempt reconstruction by the customer so as to prevent failure.

2. Before operating the unit

Precautions when installing the unit

Warning

9. Be sure to connect the ground wire.



- When the unit has no ground terminal, class D grounding work is necessary and please consult your dealer or our customer service center.



- Securely connect to a distribution board or an outlet.

We recommend use of a ground type outlet tap. When a bipolar type outlet tap is used

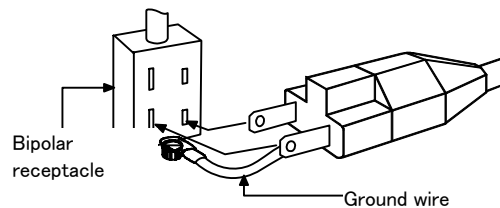
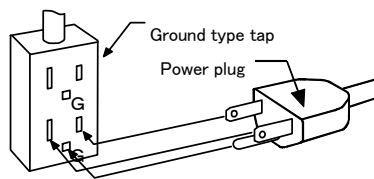

Insert the ground adaptor included as an option, into a power plug confirming the polarity of the outlet. Connect the grounding wire (green) of the ground adaptor to the ground terminal on the power supply equipment.

When there is no ground terminal.

In this case, class D grounding work (100Ω or less) is necessary and please consult your dealer or our customer service center.

Do not connect the grounding wire to any parts or lines other than a correct grounding terminal such as a gas pipe, a water pipe or a telephone line.



Otherwise, an accident or a malfunction may result.

10. Use a dedicated outlet for the power supply.



Use a power supply that meets the electrical capacity of the unit.

Electrical capacity: : **AC100V 50/60Hz 5A**



- * When the unit will not start even when you turn the refrigerator switch to "ON", check for abnormal main voltage or if the unit is connected to the same power supply line as other devices and connect it to another line if necessary. Avoid using wire extensions using a cord reel, which may result in degradation of freezing capacity or stoppage of refrigerator from possible voltage drops. Do not connect too many wires to a single outlet using a branching adaptor. Otherwise, a fire or an electric shock may result.

2. Before operating the unit

Precautions when installing the unit



11. About handling of power cords

-  • Never use electrical power cords bundled. When these are used bundled, they might overheat causing a fire.
- Do not convert, forcibly bend, twist or pull the power cord. Otherwise, a fire or an electrical shock may result.
- Do not place the power cord under a desk or a chair, or sand between objects to avoid it from being damaged.
Otherwise, a fire or an electrical shock may result.
- Do not place the power cord close to a stove or other heat generating device. Sheath of the cord may burn and result in a fire or an electrical shock.
-  • If the power cord should be damaged (exposure of core wire or disconnection), immediately turn the power switch of the main body off, pull off the power plug and ask your dealer to replace the cord. If the unit is operated with a damaged power cord, a fire or an electrical shock may result.
- Connect the power cord to an appropriate wall outlet.

2. Before operating the unit

Installation procedures/precautions

- (1) Release the stopper lock of the caster wheels.
Set the stoppers of the caster wheels to the high position as shown in the drawing in the right.
Now the lock is released.
(Only two caster wheels at the front of the unit have stoppers.)

- (2) Transport the unit to the installation place
※ Transporting the unit over a gap may give an excessive shock to the caster wheels and may damage them.
If such trouble is expected, lift the unit and transport it over the gap.
※ When lifting, never allow the product to tilt or lay on its side.

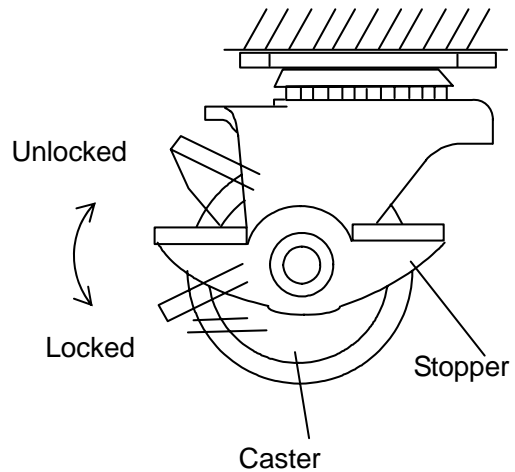

- (3) When the installation place has been determined, lock the product by pressing down the caster stopper lever.

- (4) Check the drain plug.
※ Confirm that the drain plug has not been removed.

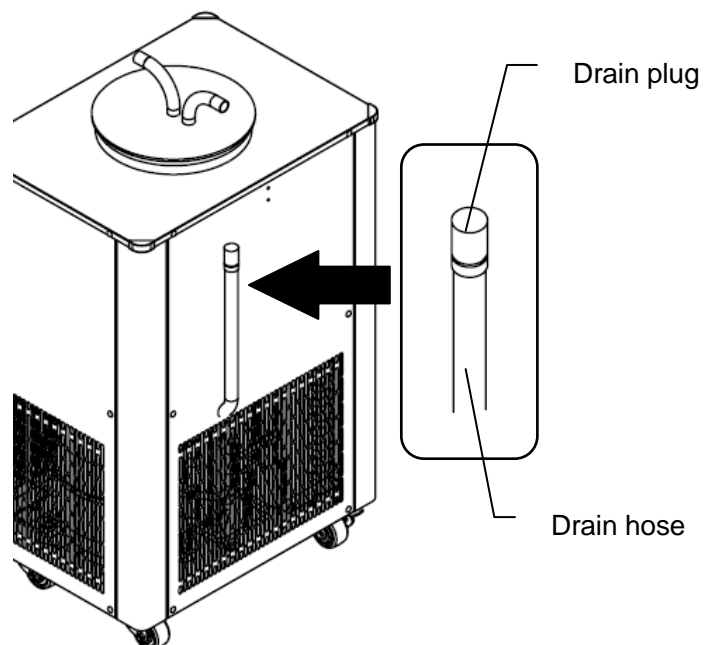

- (5) Connect the power plug

Confirm that the power switch (earth leakage breaker) is OFF and the refrigerator switch is OFF. Connect the power plug to the socket outlet.

3.Name and Functions of Parts

Main body

Front view

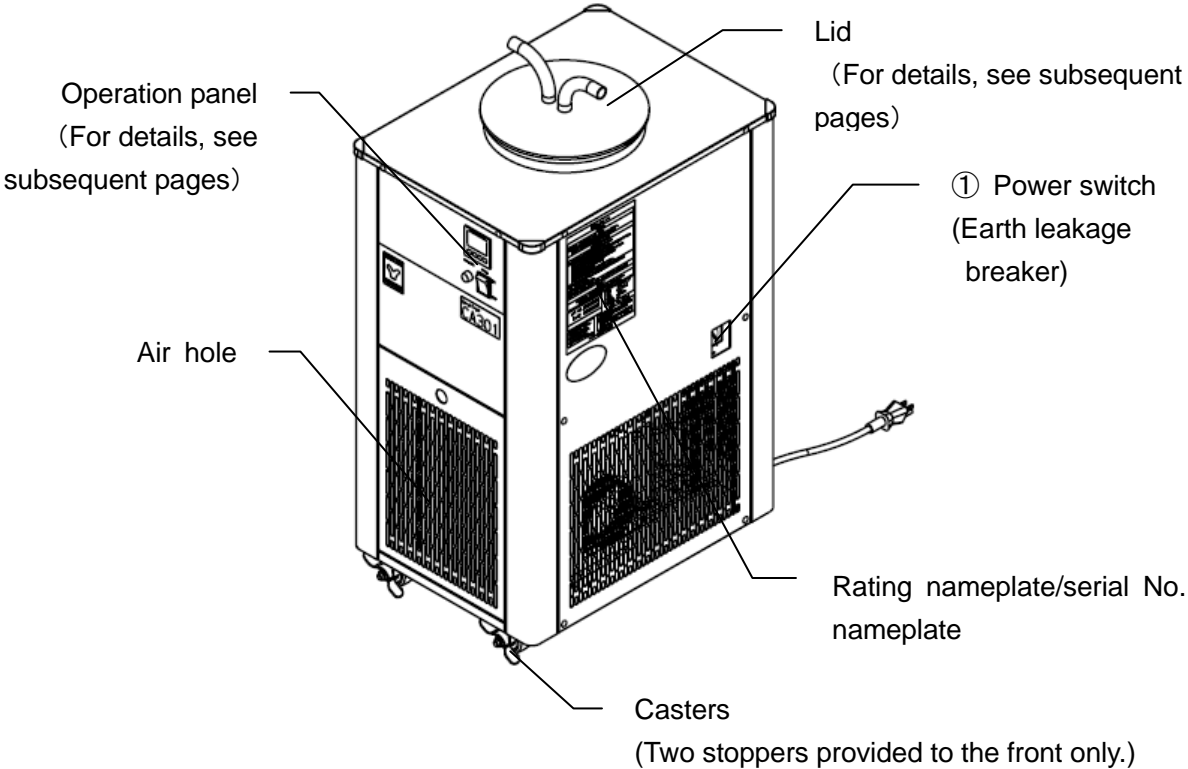

Rear view

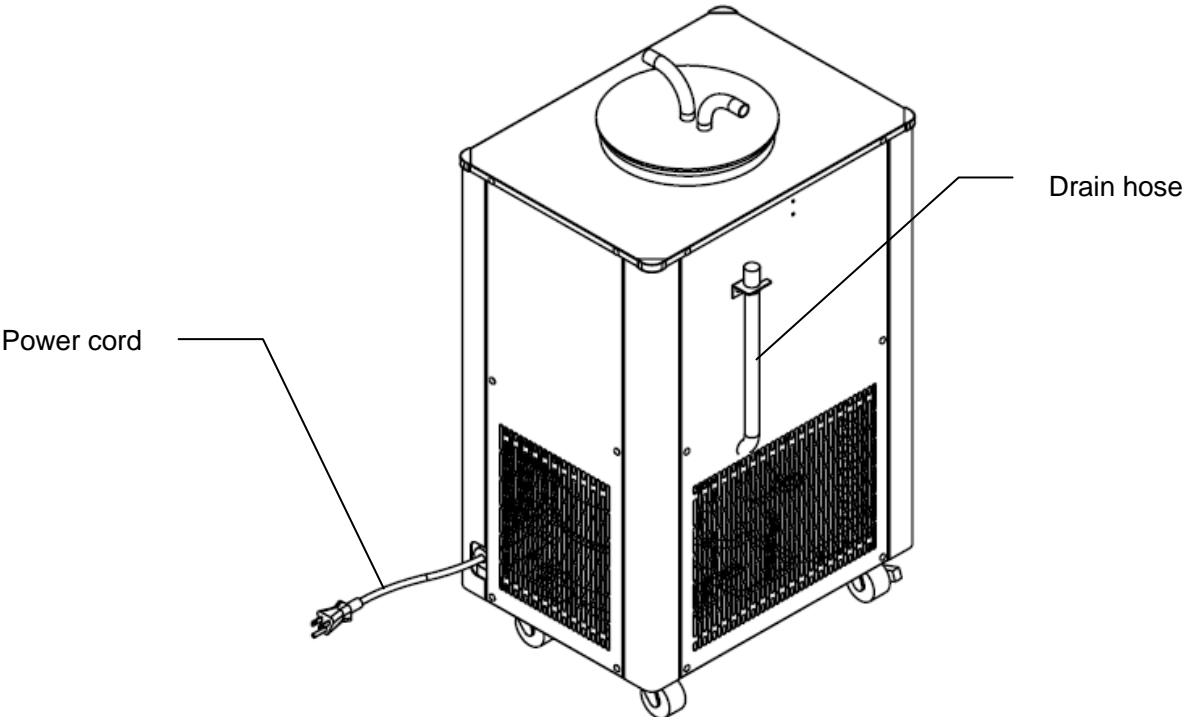

3.Name and Functions of Parts

Details of each component

Operation panel

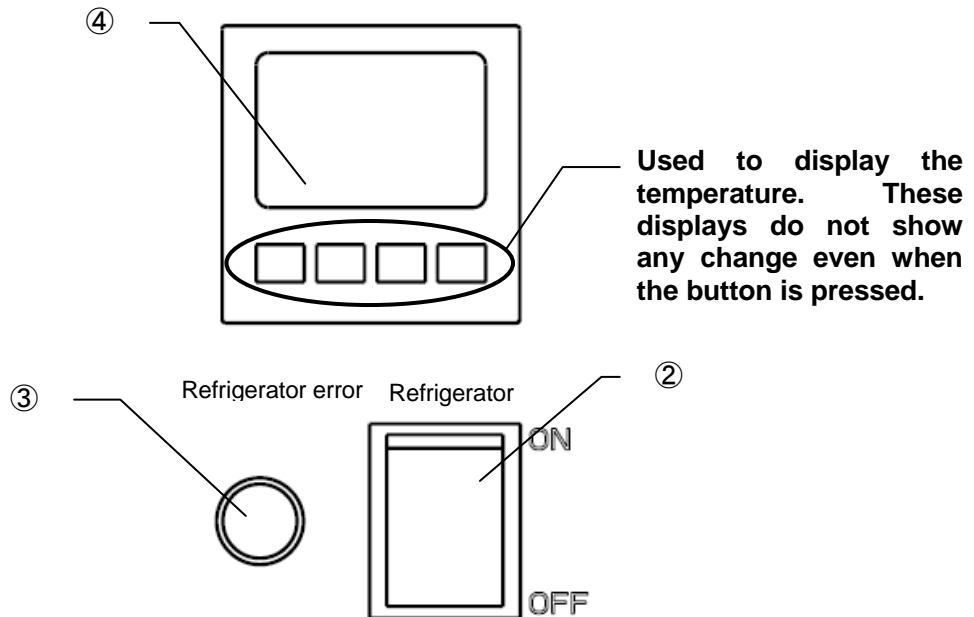

No.	Nomenclature	Control/operation
①	Power switch (earth leakage breaker)	Power switch to turn ON/OFF main power supply
②	Refrigerator switch	With this switch ON, the switch lamp goes ON and the refrigerator starts operation.
③	Refrigerator error lamp	ON when the refrigerator is overloaded
④	Temperature indicator	Shows the temperature of cooling coil in the cold trap. ※Used to display the temperature. The indicator does not show any change even when the button is pressed

Lid

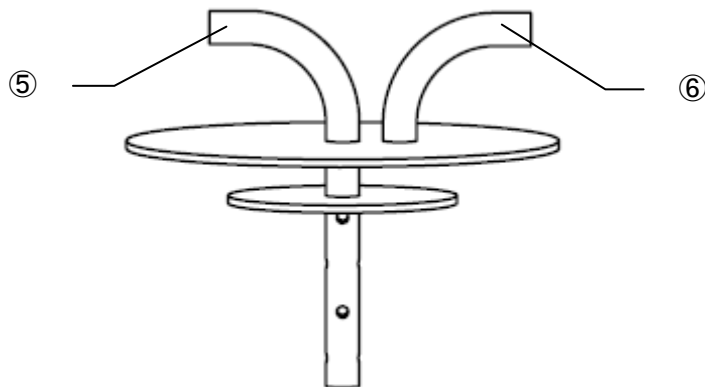

No.	Nomenclature	Control/operation
⑤	IN side	Connect to the vacuum equipment.
⑥	OUT side	Connect to the vacuum pump.

4.Operation Method

Operation method

For aqueous liquids to be trapped, take the following procedure.

For acidic or organic solvent liquids, use the glass condenser set (optional).

For the operation method, refer to the manual attached to the glass condenser set.

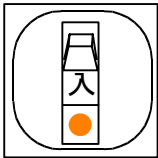
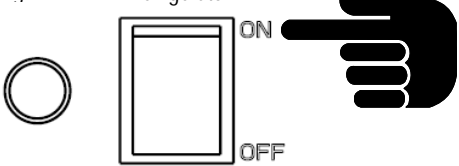
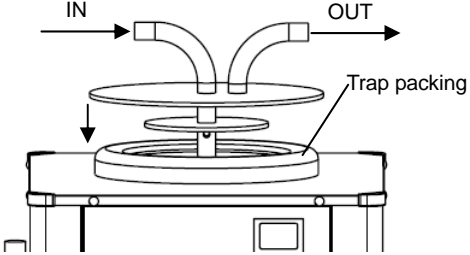
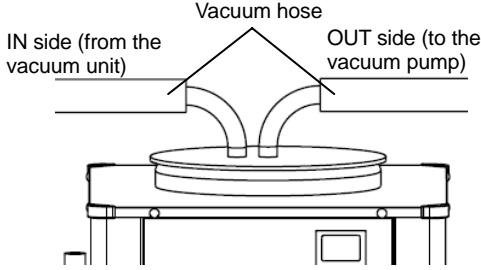
1.	Turn ON the power switch (earth leakage breaker). 	Turn ON the power switch (earth leakage breaker) on the right side.
2.	Turn ON the refrigerator switch. Refrigerator error Refrigerator 	Turn ON the refrigerator switch. The switch lamp goes ON and the refrigerator starts operation. ※ The starting sound may become louder during the initial period of operation or depending on the ambient environment and temperature, but this is not a trouble.
3.	Set the lid with nozzle. 	① Confirm that the trap packing and the lid with nozzle are free from adhesion of any dust. ※ Damage or dust adhesion, if any, may deteriorate the degree of vacuum inside the trap tank. ② Set gently the lid with nozzle on the trap packing while ensuring that “IN” and “OUT” are in the correct direction. ※ If the lid is not in tight contact with the trap packing, vacuum leak may occur.
4.	Connect the vacuum hose. 	Connect the “IN” side of the lid with nozzle to the vacuum unit and the “OUT” side to the vacuum pump via the vacuum hose. ※ Before connection, be sure to turn OFF the refrigerator switch. ※ The nozzle of the lid is positioned on the “IN” side and the “OUT” side respectively. Take care to avoid wrong connection. ※ The vacuum hose is not included in accessories. Procure the vacuum hose of 12 mm or 15 mm in inside diameter separately.
5.	Run the vacuum pump.	Turn ON the vacuum pump switch. Vapor generated in the vacuum unit is trapped in the tap tank.

4.Operation Method

Operation method

For aqueous liquids to be trapped, take the following procedure.

For acidic or organic solvent liquids, use the glass condenser set (optional).

For the operation method, refer to the manual attached to the glass condenser set.

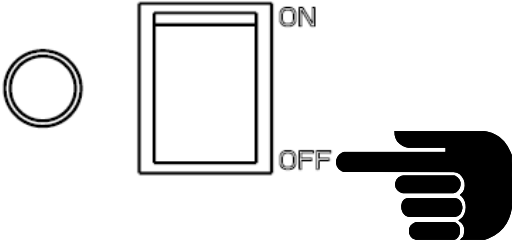
6.	<p>Turn OFF the refrigerator switch.</p> <p>Refrigerator error Refrigerator</p> 	<ol style="list-style-type: none">① Turn OFF the refrigerator switch to stop the trap.② Disconnect the vacuum hose from “IN” and “OUT” nozzles.③ Turn OFF the vacuum pump.④ Allow ice in the trap to thaw in air or thaw it by pouring hot water. When ice has been thawed, remove the drain plug to discharge the entire amount. <p>Caution : To prevent oil backflow in the vacuum pump, return the vacuum pump switch to the atmospheric pressure once, then turn it OFF (this is to purge air).</p>
7.	<p>Turn OFF the power switch (leakage breaker).</p>	<p>Turn OFF the power switch (leakage breaker) on the right side.</p>

Caution

- Be sure to confirm that the circulation hose has been connected before operation.

4.Operation Method

Cooling curve (reference data)

1. Surface temperature of the cooling coil without any load in the trap (no-load state)

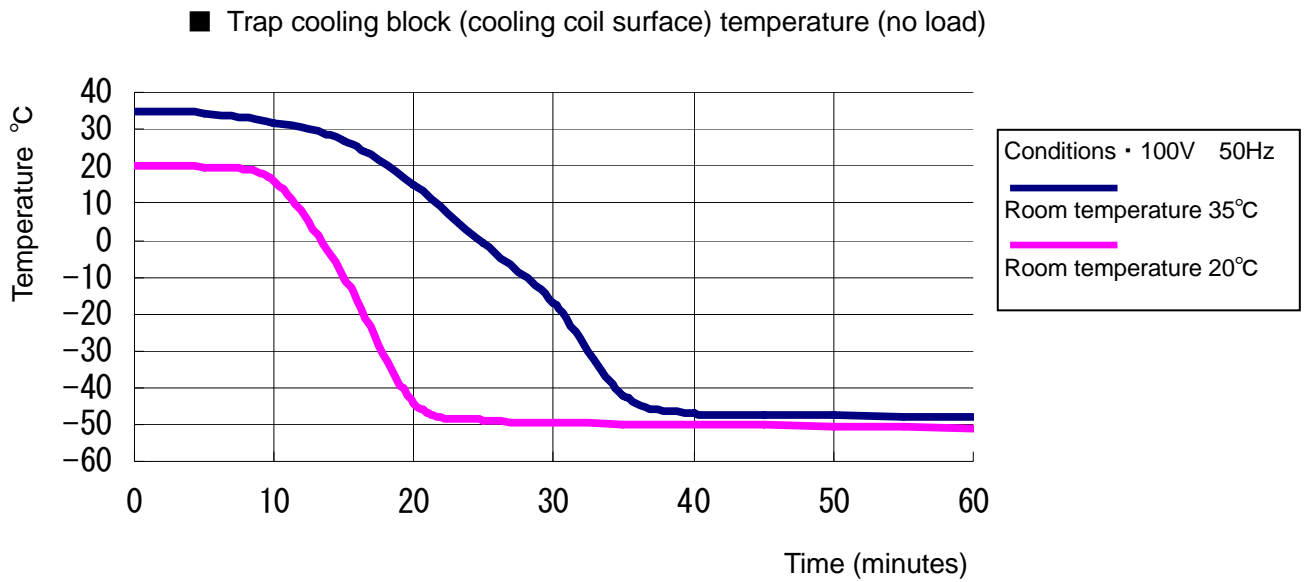

2. Liquid temperature with the trap filled by 3 L of ethanol (loaded state)

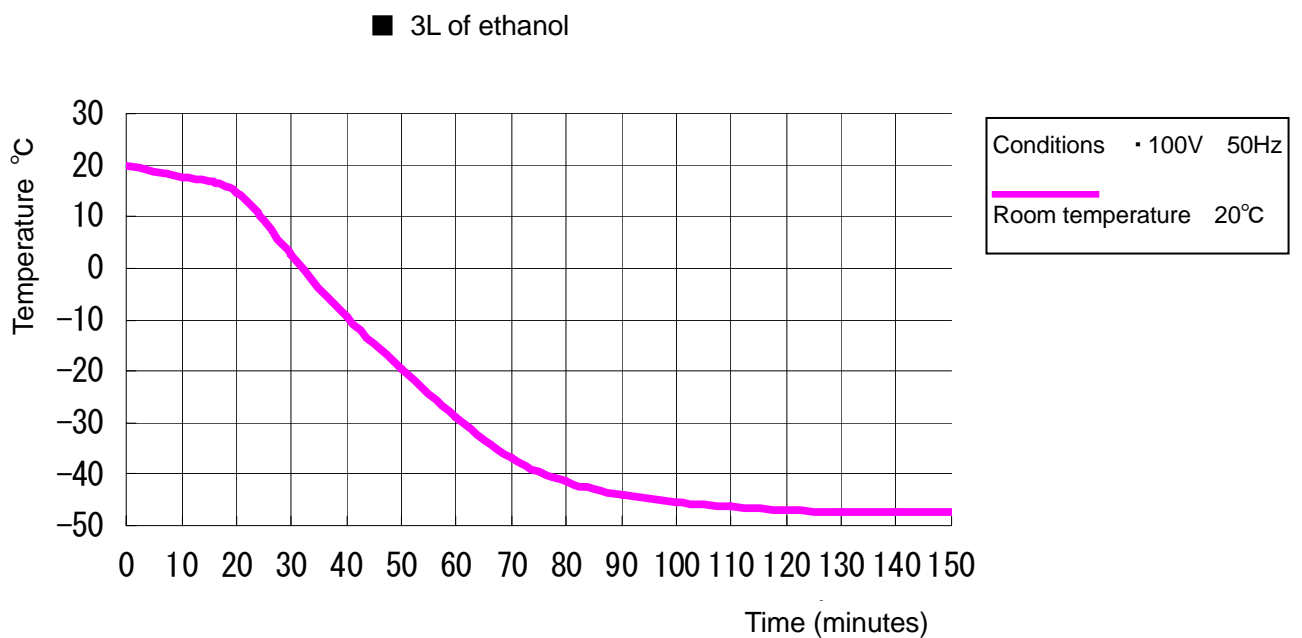

5.Cautions for Handling

Warning

1.Handling of flammable and combustible solutions

-  This product is not of an explosion-proof structure. For samples to be handled with this trap, specifically, for explosive and combustible substances and any substances containing these substances. pay particular attention. If left at the room temperature (or below for certain solutions), flammable and combustible solutions may be vaporized and thus ignited and exploded by any ignition source (switch, etc.). Ensure sufficient ventilation during operation. (See "13. List of Hazardous Substances" of P.23.)

2. Ban on use/countermeasures when an error occurs

-  If smoke is emerges on the unit or an odd odor is felt, immediately turn the power supply on the main unit off, turn the power source off and contact your dealer, a Yamato sales office or our customer service center for inspection. Otherwise, a fire or an electrical shock may result. The user shall never attempt to repair the unit to avoid any possible dangers.

Caution

1. Maximum trap capacity

-  The maximum trap capacity for the aqueous system is about 0.9Kg. Filling the trap beyond this limit may cause clogging of "IN" and "OUT" nozzles.

2. Never climb on the unit.

-  Never climb on the unit. The unit may topple over or be damaged and a personal injury or a malfunction may result.

3.Do not place objects on the unit.

-  Do not place objects on the unit. They may fall and cause a personal injury.

4. When a thunder is heard.

-  When a thunder is heard, immediately turn the ELB of the main unit and the power supply off. Leaving it as it is may cause a fire from lightening.

5.Thoroughly wash the unit.

-  Although the unit has been washed at the time of shipping, wash it thoroughly when you are going to use it for the first time or use after it has been left unused for an extended period.

6. During nighttime and when the unit will be left stopped for an extended period.

- 
- Turn the ELB to "OFF" and remove the power plug during nighttime and when the unit will be left stopped for an extended period of time.
 - Drain liquid at the drain cock from the circulation system if you are not going to use the unit for an extended period of time.

5. Cautions on handling



7. About recovery from a power failure.



When a power failure occurs during operation and power supply recovers, the unit will automatically return to the state immediately before that power failure and resume operation. Turn the ELB off if you do not want to recover and resume operation automatically.

8. About abnormal pressure of the chiller (Refrigerator overload relay)



Operating the refrigerator at a high temperature range may activate the refrigerator overload relay protection circuit and stop the refrigerator

9. Cautions for re-startup



When turn OFF the refrigerator switch once and turn it ON again, take three or more minutes of interval. Otherwise, the refrigerator overload relay protective circuit is activated, disabling startup of the refrigerator.

10. About condensation



Condensate may generate depending on the operating conditions or the environment. Wipe any condensate with a dry cloth or a rag.

11. When transporting the unit



Do not hold the unit on its side when you lift it for transportation.
Observe the installation procedures (P.4~8) when reinstalling the unit.

6. Maintenance

Daily inspection/maintenance

We strongly recommend daily inspection and maintenance to assure stable operation of the unit.

Warning

- Be sure to remove the power cord before inspection or maintenance unless necessary.
- Start working after the unit temperature has returned to the normal temperature.
- Never attempt to disassemble devices.
- Never touch the condenser fins with bare hands.

Caution

- Wipe off any dirt with a well wrung out soft cloth. Never use benzene, thinner, or scorching powder or rub with a hard brush. Otherwise, deformation, deterioration, or discoloration may result.

Monthly

- Inspect the function of the ELB.
Connect the power cord and conduct a test while it is activated.
 - First turn the ELB “off”.
 - Then turn it “on” and push the test button of the ELB with a pointed object such as a ball point pen and it is normal if it is turned off.

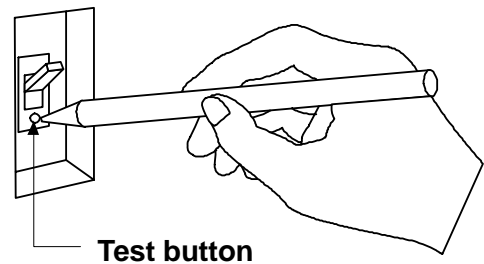

Clean the air vent.

Clogged filter will degraded cooling efficiency. It also may cause a malfunction of the freezer. Extent of clogging will differ depending on the environment or operating time and clean the filters at a regular interval appropriate for the specific operating conditions.

- Remove the filter unit from the main body and remove dust adhering to the condenser surface by a cleaner.
- Take out the filter from the filter unit and wash it or clean to remove dust with a cleaner.
- When cleaning is over, reinstall by reversing the above procedure.



- Take care not to break the fins.
- Take care not to cut hands with fins.

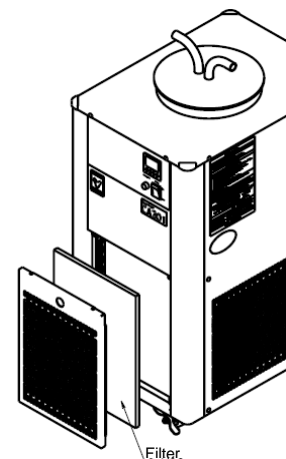

When the unit is not to be used for a long time or when disposing

When the unit is not to be used for a long time or when disposing



Caution

When the trap is not to be used for a long period of time

- Turn OFF the earth leakage breaker and disconnect the power cord.
- Wipe off moisture in the trap completely.



Warning

When you are going to discard the product

- The unit uses replacing Fluorocarbon.
Ask a professional for disposal of Fluorocarbon according to the Fluorocarbon Recovery and Destruction law.
- Never leave the unit at a place where children may access.
- Normally, dispose of the trap as industrial waste.

Requests in case of disposal

Pay due attention on conservation of the global environment.

- When disposing, it is essential to disassemble as much as possible for segregated disposal or recycling by considering the environmental conservation. Principal components and materials used of this trap are as shown below.

Names of major parts	Major materials
Major components of the outer finish	
Outer finish	Chromium-free electro galvanized steel plate (SECC), Chemical-proof bake coating
Internal bath	SUS304 stainless steel
Nameplate	Polyethylene (PET) resin film
Corner	Alkyl benzene sulfide resin (ABS resin)
Trap packing	Silicon rubber
Principal components of electric system	
Switches, relays, temperature indicators	Resin and other synthetic materials
Power cord and wiring materials, others	Synthetic rubber cover, copper, nickel, and other compounds
Principal components of refrigerator system	
Refrigerator system	Ferrous and synthetic oil, etc.
Condenser fins	Al and copper
Principal components of piping system	
Drain hose	Natural rubber
Drain plug	Polyacetal
Drain plug holder	Bonderizing steel plate, melamine resin baking finishing
Pipe cover	Polyurethane sponge
Pipe	Copper pipe
Refrigerant filled in the refrigerator	
Refrigerant※	R404A

※ For disposal of the refrigerant, request the contractor specialized in this field.

8. Troubleshooting Guide

Check list

For the following condition

Symptom	Check as follows
Failure to startup even when the switch is turned ON	<ul style="list-style-type: none"> ● Check if the power cord is firmly connected to the socket outlet. ● Check for power failure. ● Check if the power switch (earth leakage breaker) is OFF.
Temperature does not drop	<ul style="list-style-type: none"> ● Check the condenser fins are clogged. ● Check if the heat load of coolant of trapped sample is excessively large. ● Check if the ambient temperature is high. (Check if the temperature has exceeded 35°C.) ● Check if the area around air vent is blocked.

For lamp ON

Error sign	Cause	Countermeasure
Refrigerator error lamp ON	Refrigerator overload	Turn OFF power supply immediately and remove the cause of trouble in "Check list; Temperature does not drop." After taking a certain time, turn ON power supply again. If the error lamp goes ON again, call the service center.

If power outage occurs

When the power is applied again after the unit has stopped due to power outage, the unit will automatically return to the status immediately before the power outage and resumes operation. Turn the ELB off if you do not want to resume operation by automatic recovery.

- ◆ If none of above factors are found applicable, turn OFF power switch immediately and shut off the master power supply. Contact the shop from which you have purchased the product or our sales office, or our customer service center.

9. After sales service and warranty

When requesting a repair

When requesting a repair

If any trouble occurs, immediately stop operation, turn the power switch (ELB) off, pull out the power plug (power cord) and contact your dealer or our sales office.

Information necessary for requesting a repair

- Model name of the product
 - Serial number
 - Date (y/m/d) of purchase
 - Description of trouble (as in detail as possible)
- } See the warranty card or the nameplate on the unit.
} See the section "Names and Functions of Parts" on page 9

Be sure to indicate the warranty card to our service representative.

Warranty card (attached separately)

- Warranty card is given by your dealer or one of our sales offices and please fill in your dealer, date of purchase and other information and store securely.
- Warranty period is one full year from the date of purchase. Repair service for free is available according to the conditions written on the warranty card.
- For repairs after the warranty period consult your dealer or one of our sales offices. Paid repair service is available on your request when the product's functionality can be maintained by repair.

Minimum holding period of repair parts

The minimum holding period of repair parts for this product is seven years after end of production.

Repair parts here refer to parts necessary for maintaining performance of the product.

10. Specifications

Main body specifications

Model		CA301
System		Direct trap or glass trap (optional)
Performance ※1	Dehumidification capacity	Max 0.9Kg (aqueous system)
	Lowest achieving temperature ※2,3	-45°C
	Time to achieve the lowest achieving temperature ※3	20 minutes or less (+20°C → -45°C)
Composition	Refrigerator	Air-cooling type 400W
	Refrigerant	R404A 116g±4g
	Cooling coil	I.D.: φ90mm SUS304
	Lid	SUS304 O.D: φ17.6mm, with nozzle
	Tank shape and material	Cylindrical SUS304
	Ambient temperature range	5~35°C
	Temperature indicator ※4	7-segment LED
	Temperature sensor	Platinum resistance temperature detector Pt100Ω
Defrosting mechanism		None
Safety devices		Over-current leakage breaker, refrigerator overload relay
Other functions		Drain (vacuum hose with plug)
Standard	Tank size	I.D φ153mm × height 235mm
	Inner volume	About 4L (liquid level 3L)
	Power supply, rated current value ※5	AC100V 50/60Hz 5A(15A)
	Outer size ※6	W345mm × D475mm × H726mm
	Mass	About 47kg
Accessories		Operation manual, guarantee card

※1 The performance applies to the conditions with room temperature of 23°C±5°C, humidity of 65% RH±20%, rated supply voltage of AC100V/50Hz, and without load.

※2 The lowest achieving temperature is the temperature of the cooling coil surface.

※3 The applies to the case when the cold trap is used as an air tank.

※4 The indicator temperature is the temperature of the cooling piping surface.

※5 The current value in () represents the breaker capacity.

※6 Projection not included

Option

Nomenclature	Article No.	Features
Glass condenser set, type OCA10	221487	For trapping of acidic and organic solvents
Different-diameter pipe for rubber tube		Used when the connection size is different
Brass φ30 × φ18	242185	
Brass φ30 × φ12	242186	
SUS φ30 × φ18	241496	
SUS φ30 × φ12	241497	
SUS-made lid	281296	Lid of trap tank

11.Connection Diagram

Connection diagram

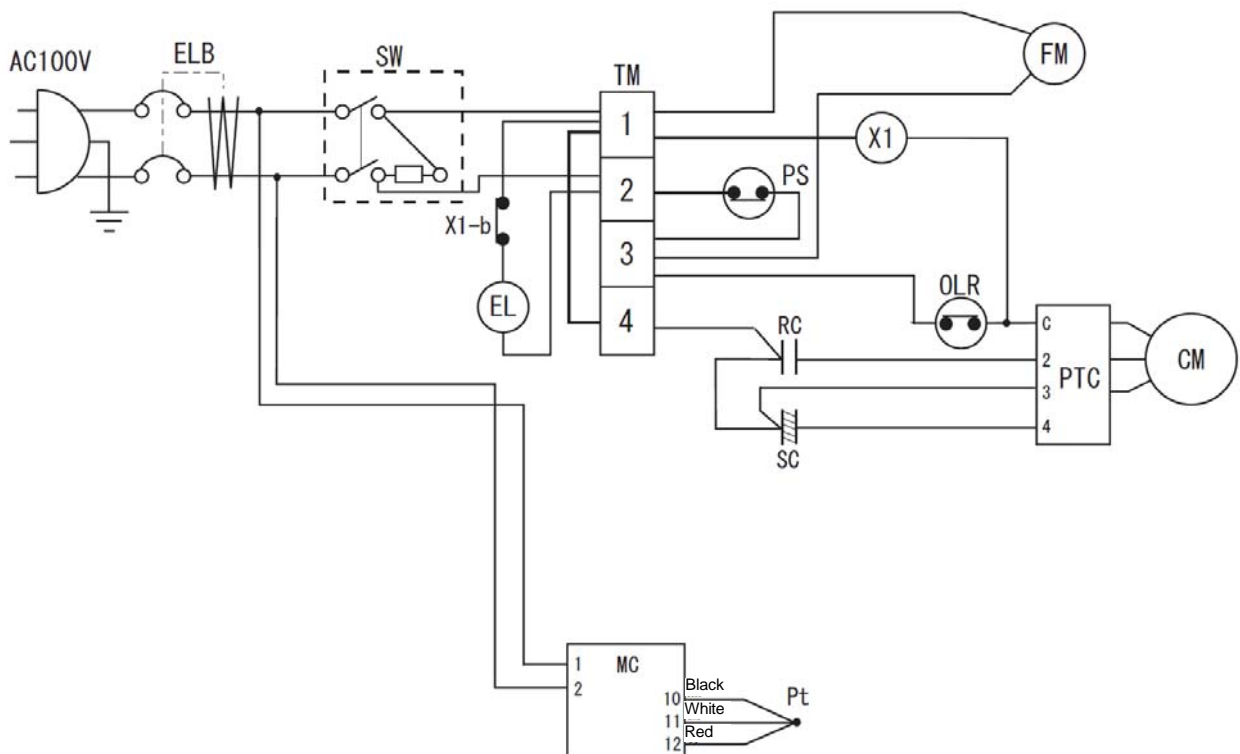

Symbol	Name of parts	Symbol	Name of parts
ELB	Earth leakage breaker	EL	Refrigerator error lamp
SW	Refrigerator switch	PS	Pressure switch
TM	Terminal board	RC	Running condenser (CM)
X1	Relay	SC	Starting condenser
OLR	Overload relay	FM	Fan motor
MC	Temperature indicator	CM	Compressor motor
Pt	Pt sensor	PTC	PTC starter

12.Replacement Parts List

Symbol	Name of parts	Code No.	Specifications	Manufacturer
-	Trap packing	CA30030150	Silicon	Yamato Science
-	Drain hose	3040016022	Φ6 × Φ18	Yamato Science
-	Drain plug	CA30040200	Polyacetal	Yamato Science
ELB	Power switch (Earth leakage breaker)	LT00029774	NV-L22GR 15A 30MA	Mitsubishi Electric
SW	Refrigerator switch	LT00021833	LLK35L1	OTAX
X1	Relay	A0089	AP3822K	Panasonic
MC	Temperature indicator	LT00034914	TTM-204Q-RI-RUV	Toho Denshi
EL	Refrigerator error lamp	W0062	BN5701 100V Red	Sato Parts

13. List of dangerous materials



Never use an explosive substance a flammable substance or a substance containing them for this device.

Explosive substance	Explosive substance	① Nitroglycol, glycerine trinitrate, cellulose nitrate and other explosive nitrate esters
		② Trinitrobenzen, trinitrotoluene, picric acid and other explosive nitro compounds
		③ Acetyl hydroperoxide, methyl ethyl ketone peroxide, benzoyl peroxide and other organic peroxides
		④ Metallic azide, including sodium azide, etc.
Flammable substances	Explosive substances	① Metal "lithium" ② metal "potassium" ③ metal "natrium" ④ yellow phosphorus ⑤ phosphorus sulfide ⑥ red phosphorus ⑦ phosphorus sulfide ⑧ celluloids, calcium carbide (a.k.a, carbide) ⑨ lime phosphide ⑩ magnesium powder ⑪ aluminum powder ⑫ metal powder other than magnesium and aluminum powder ⑬ sodium dithionous acid (a.k.a., hydrosulphite)
	Oxidizing substances	① Potassium chlorate, sodium chlorate, ammonium chlorate, and other chlorates
		② Potassium perchlorate, sodium perchlorate, ammonium perchlorate, and other perchlorates
		③ Potassium peroxide, sodium peroxide, barium peroxide, and other inorganic peroxides
		④ Potassium nitrate, sodium nitrate, ammonium nitrate, and other nitrates
		⑤ Sodium chlorite and other chlorites
		⑥ Calcium hypochlorite and other hypochlorites
	Flammable substances	① Ethyl ether, gasoline, acetaldehyde, propylene chloride, carbon disulfide, and other substances with ignition point at a degree 30 or more degrees below zero.
		② n-hexane, ethylene oxide, acetone, benzene, methyl ethyl ketone and other substances with ignition point between 30 degrees below zero and less than zero.
		③ Methanol, ethanol, xylene, pentyl n-acetate, (a.k.a.amyl n-acetate) and other substances with ignition point between zero and less than 30 degrees.
		④ Kerosene, light oil, terebinth oil, isopenthyl alcohol(a.k.a. isoamyl alcohol), acetic acid and other substances with ignition point between 30 degrees and less than 65 degrees.
	Combustible gas	Hydrogen, acetylene, ethylene, methane, ethane, propane, butane and other gases combustible at 15°C at one air pressure.

Excerpt from Table 1, Hazardous Substances, of the Cabinet Order of the Occupational Safety and Health Law (substances related to Articles 1, 6, and 9)

14. Standard installation manual

* Install the product according to the following: (Confirm separately for optional items or special specifications)

Model	Serial number	Date	Installation mgr.(company name)	Installation mgr.	Judgment

No.	Item	Implementation method	TOC No. Reference page of the operating instruction manual	Judgment
Specifications				
1	Accessories	Check for number of accessories on the basis of the column for accessories.	10. Specifications field P.20	
2	Installation	<ul style="list-style-type: none"> Visual check of environmental conditions Caution: Take care for environment	2. Before operating the unit <ul style="list-style-type: none"> On the installation site P.4	
		<ul style="list-style-type: none"> Securing a space 		
Operation-related matters				
1	Source voltage	<ul style="list-style-type: none"> Measure the user side voltage (outlet, etc.) with a tester Measure voltage during operation (shall meet the specifications) Caution: Always use a plug that meets the specification for attaching to the ELB.	2. Before operating the unit <ul style="list-style-type: none"> Be sure to connect the ground wire. P.6 Power supply is P.6 10.Specifications <ul style="list-style-type: none"> Specification - power supply P.20 	
2	Operation start	<ul style="list-style-type: none"> Start operation. 	4. Installation procedures P. 8 5. Operation method P.11 ~ Operation method 12	
Description				
1	Operational descriptions	<ul style="list-style-type: none"> Explain the customer about each assembly as per the operation manual. 	5. Operation method P.11 ~ Operation method 12 1. Safety precautions ~13. List of dangerous materials P.1~23	
2	Error codes	Explain the customer about error codes and procedures for release according to the operational instructions	8. Troubleshooting P.18	
3	Maintenance and inspection	Explain operations of each component according to the operational instructions	7. Maintenance procedures <ul style="list-style-type: none"> Daily inspection/ maintenance P.16 	
4	Completion of installation Entries	<ul style="list-style-type: none"> Fill in the installation date and the installation mgr. on the nameplate of the main unit Fill in necessary information to the warranty card and hand it over to the customer Explanation of the route for after-sales service 	9. After sales service and warranty P. 19	

Limited liability

Be sure to use the unit strictly following the handling and operating instructions in this operating instruction.

Yamato Scientific Co., Ltd. assumes no responsibility for an accident or a malfunction caused by use of this product in any way not specified in this operating instruction.

Never attempt to perform matters prohibited in this operation instruction.

Otherwise, an unexpected accident may result.

Notice

- **Descriptions in this operating instruction are subject to change without notice.**
- **We will replace a manual with a missing page or paging disorder.**

Instruction Manual
Cold Trap

CA301

First edition November 11, 2011

Revised M a y , 11, 2012

Yamato Scientific Co., Ltd.
〒103-8432
2-1-6, Nihonbashi, Honcho, Chuo-ku,
Tokyo
Customer support center
 Tool free: 0120-405525
<http://www.yamato-net.co.jp>